

Section 2

Maximum Security Vehicular Gate Operators

Slide Gate Operators

Model 9210	2
Model 9220	3
Model 9230	4
Model 9235	5
Model 9240	6
Model 9530	7
Model 9550	8
Model 9555	9
Accessories	10

Secondary & Vehicular Reversing Devices

Secondary Entrapment Protection Devices Type B1 and B2	See Section 1, Pg 18
Loop Detectors and Loops	See Section 1, Pg 19

Gate Operator Accessories

Gate Operator Control Stations	See Section 1, Pg 20
Postal and Fire Department Lock Boxes	See Section 1, Pg 21
Time Clocks, Surge Suppressers, Traffic Signal	See Section 1, Pg 22
Accessory Transformers	See Section 1, Pg 23

Model 9210

Slide Gate Operators

9210 Series operators are designed to operate vehicular sliding gates used in Limited (Class III) and Restricted (Class IV) industrial and maximum security applications only. These operators have a full feature circuit board and are available with #50 or #60 chain. Chain support tray (p/n 2601-270) should be used on gates exceeding 20 feet in length and the heavy-duty mounting pedestal is recommended for gates weighing over 1500 Lbs.

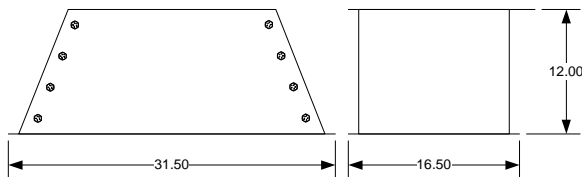
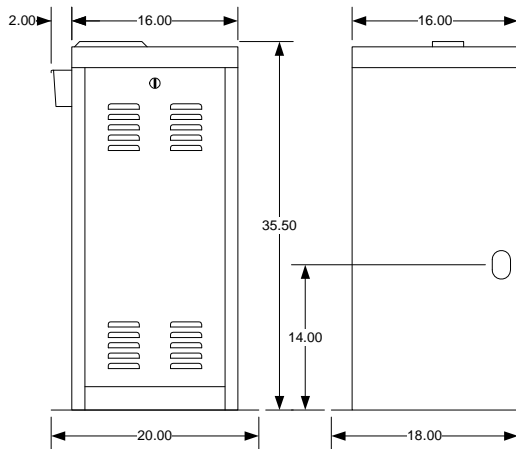

9200-135

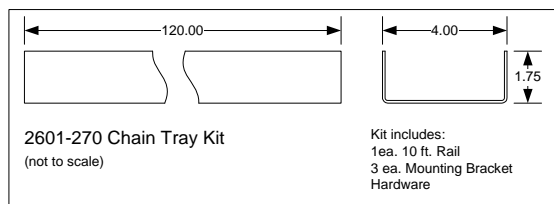

Operators w/ #50 Chain

9210-080 1 HP, 115V	3607.50
9210-082 1 HP, 208V 1 ^Ø	3625.50
9210-084 1 HP, 230V 1 ^Ø	3625.50
9210-086 1 HP, 208V 3 ^Ø	3690.00
9210-088 1 HP, 230V 3 ^Ø	3690.00

Operators w/ #60 Chain

9210-081 1 HP, 115V	3772.50
9210-083 1 HP, 208V 1 ^Ø	3817.50
9210-085 1 HP, 230V 1 ^Ø	3817.50
9210-087 1 HP, 208V 3 ^Ø	3855.00
9210-089 1 HP, 230V 3 ^Ø	3855.00

Accessories

9200-135 Heavy-duty mounting pedestal.....	679.50
2601-270 Chain Tray Kit 10-ft.	262.50
2600-485 20-ft #50 chain.....	127.50
2600-448 20-ft #60 chain.....	142.50
1601-195 Heater 115 VAC	420.00
1601-197 Heater 208/230 VAC	420.00
Slide gate accessories	Sec 1, Pg 14-16
Secondary entrapment prevention devices	Sec 1, Pg 18
Loops and loop detectors	Sec 1, Pg 19
Gate operator control stations	Sec 1, Pg 20
Postal & Fire Dept Lock Boxes.....	Sec 1, Pg 21
Time Clocks & Surge Suppression	Sec 1, Pg 22

9210 Maximum Capacities				
Model	Maximum Speed	Chain	Max Gate Weight (lbs.)	Max Gate Width (ft.)
9210	1 ft/sec	50	2000	100
9210	1 ft/sec	60	3000	100

Model 9220

Slide Gate Operators

9220 Series Variable Speed operators feature slow-start / slow-stop operation and are designed to operate vehicular sliding gates used in Limited (Class III) and Restricted (Class IV) industrial and maximum security applications only. These operators have a full feature circuit board and are available with #50 or #60 chain. Chain support tray (p/n 2601-270) should be used on gates exceeding 20 feet in length and the heavy-duty mounting pedestal is recommended for gates weighing over 1500 Lbs.

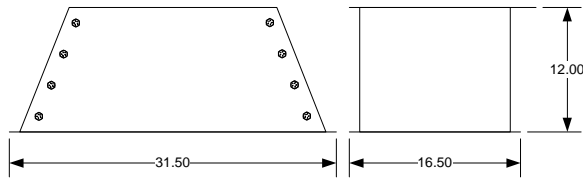
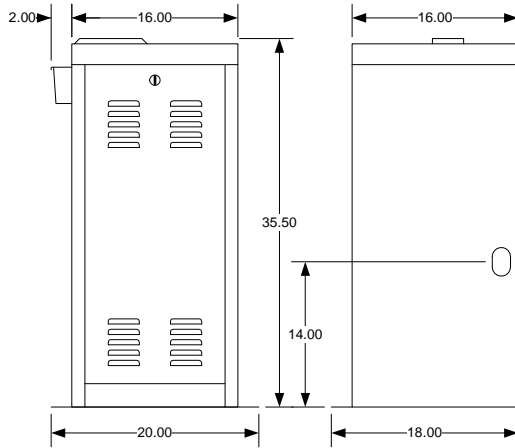

9200-135

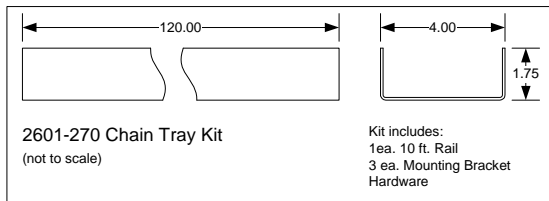

Operators w/ #50 Chain

9220-080 2 HP, 208V 1 ^Ø	4462.50
9220-082 2 HP, 230V 1 ^Ø	4462.50
9220-084 2 HP, 208V 3 ^Ø	4500.00
9220-086 2 HP, 230V 3 ^Ø	4500.00

Operators w/ #60 Chain

9220-081 2 HP, 208V 1 ^Ø	4627.50
9220-083 2 HP, 230V 1 ^Ø	4627.50
9220-085 2 HP, 208V 3 ^Ø	4665.00
9220-087 2 HP, 230V 3 ^Ø	4665.00

Accessories

9200-135 Heavy-duty mounting pedestal	679.50
2601-270 Chain Tray Kit 10-ft.	262.50
2600-485 20-ft #50 chain	127.50
2600-448 20-ft #60 chain	142.50
1601-197 Heater 208/230 VAC	420.00
Slide gate accessories	Sec 1, Pg 14-16
Secondary entrapment prevention devices	Sec 1, Pg 18
Loops and loop detectors.....	Sec 1, Pg 19
Gate operator control stations	Sec 1, Pg 20
Postal & Fire Dept Lock Boxes.....	Sec 1, Pg 21
Time Clocks & Surge Suppression	Sec 1, Pg 22

9220 Maximum Capacities				
Model	Maximum Speed	Chain	Max Gate Weight (lbs.)	Max Gate Width (ft.)
9220	2 ft/sec	50	1800	100
9220	2 ft/sec	60	2000	100

Model 9230

Slide Gate Operators

9230 Series Variable Speed operators feature slow-start / slow-stop operation and are designed to operate vehicular sliding gates used in Limited (Class III) and Restricted (Class IV) industrial and maximum security applications only. These operators have a full feature circuit board and come with #60 chain. Chain support tray (p/n 2601-270) should be used on gates exceeding 20 feet in length and the heavy-duty mounting pedestal is recommended for gates weighing over 1500 Lbs.

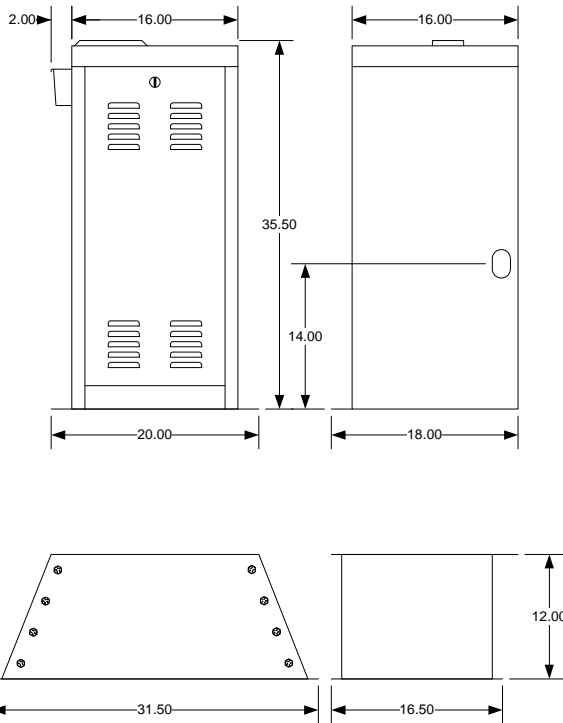

9200-135

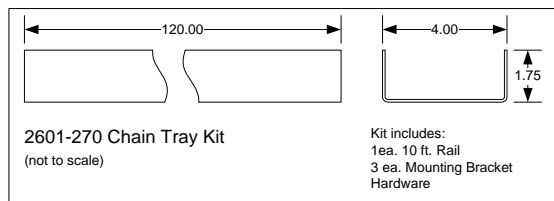

Operators w/ #60 Chain

- 9230-080 3 HP, 208V 3^Ø6165.00
- 9230-081 3 HP, 230V 3^Ø6165.00

Accessories

- 9200-135 Heavy-duty mounting pedestal..... 679.50
- 2601-270 Chain Tray Kit 10-ft. 262.50
- 2600-448 20-ft #60 chain..... 142.50
- 1601-197 Heater 208/230 VAC..... 420.00
- Slide gate accessories Sec 1, Pg 14-16
- Secondary entrapment prevention devicesSec 1, Pg 18
- Loops and loop detectorsSec 1, Pg 19
- Gate operator control stationsSec 1, Pg 20
- Postal & Fire Dept Lock Boxes.....Sec 1, Pg 21
- Time Clocks & Surge SuppressionSec 1, Pg 22

9230 Maximum Capacities				
Model	Maximum Speed	Chain	Max Gate Weight (lbs.)	Max Gate Width (ft.)
9230	2 ft/sec	60	5000	100

Model 9235

Slide Gate Operators

9235 Series Variable Speed operators feature slow-start / slow-stop operation. These operators are designed to operate vehicular sliding gates used in Limited (Class III) and Restricted (Class IV) industrial and maximum security applications that have a need for a high speed gate and emergency close features. These operators have a full feature circuit board and come with #60 chain. Chain support tray (p/n 2601-270) should be used on gates exceeding 20 feet in length and the heavy-duty mounting pedestal is recommended for gates weighing over 1500 Lbs.

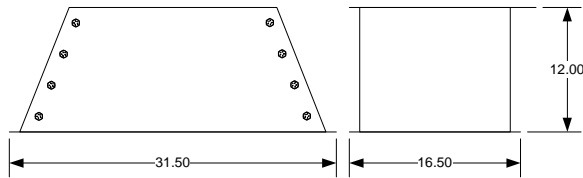
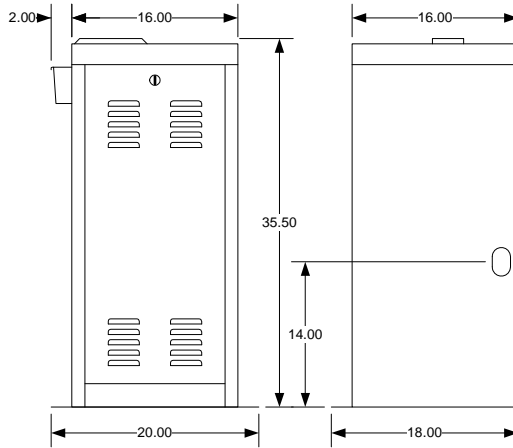

9200-135

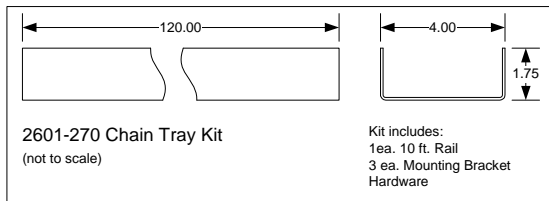

Operators w/ #60 Chain

- 9235-080 3 HP, 208V 3^Ø 9000.00
- 9235-081 3 HP, 230V 3^Ø 9000.00

Accessories

- 9200-135 Heavy-duty mounting pedestal..... 679.50
- 2601-270 Chain Tray Kit 10-ft. 262.50
- 2600-448 20-ft #60 chain 142.50
- 1601-197 Heater 208/230 VAC 420.00
- Slide gate accessories Sec 1, Pg 14-16
- Secondary entrapment prevention devices Sec 1, Pg 18
- Loops and loop detectors..... Sec 1, Pg 19
- Gate operator control stations Sec 1, Pg 20
- Postal & Fire Dept Lock Boxes..... Sec 1, Pg 21
- Time Clocks & Surge Suppression Sec 1, Pg 22

9235 Maximum Capacities				
Model	Maximum Speed	Chain	Max Gate Weight (lbs.)	Max Gate Width (ft.)
9235	4 ft/sec 6 ft/sec EC	60	3000	100

EC = Emergency Close

Model 9240

Slide Gate Operators

9240 Series Variable Speed operators feature slow-start / slow-stop operation. These operators are designed to operate vehicular sliding gates used in Limited (Class III) and Restricted (Class IV) industrial, maximum security and corrections applications. These operators use a heavy-duty 10 gauge steel cabinet, have a full feature circuit board and come with #80 chain. The heavy-duty mounting pedestal is standard with this operator. Chain support tray (p/n 2601-270) should be used on gates exceeding 20 feet in length.

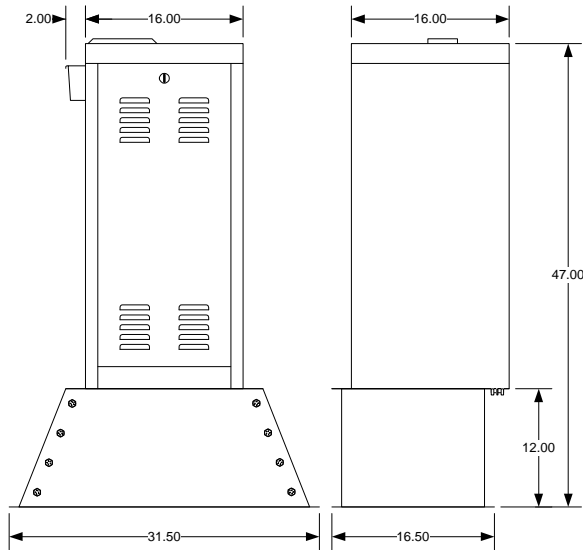

Operators w/ #80 Chain & 10 Ga. Steel Housing

9240-080 3 HP, 208V 3 ^Ø	10,620.00
9240-081 3 HP, 230V 3 ^Ø	10,620.00

Accessories

2601-270 Chain Tray Kit 10-ft.	262.50
2601-268 10-ft #80 chain.....	93.00
2601-269 20-ft #80 chain.....	186.00
1601-197 Heater 208/230 VAC.....	420.00
Slide gate accessories	Sec 1, Pg 14-16
Secondary entrapment prevention devices	Sec 1, Pg 18
Loops and loop detectors	Sec 1, Pg 19
Gate operator control stations	Sec 1, Pg 20
Postal & Fire Dept Lock Boxes.....	Sec 1, Pg 21
Time Clocks & Surge Suppression	Sec 1, Pg 22

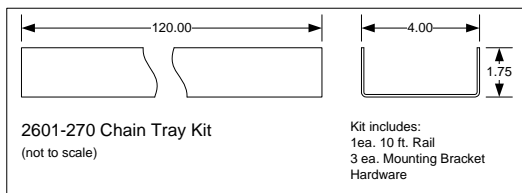

9240 Maximum Capacities				
Model	Maximum Speed	Chain	Max Gate Weight (lbs.)	Max Gate Width (ft.)
9240	2 ft/sec	80	8000	100

Model 9530

Slide Gate Operators

9530 Series Variable Speed operators feature slow-start / slow-stop operation. These operators are designed to operate very large and very heavy vehicular sliding gates used in Limited (Class III) and Restricted (Class IV) industrial and maximum security applications. These operators have a full feature circuit board and come with #80 chain. Chain support tray (p/n 2601-270) should be used on gates exceeding 20 feet in length.

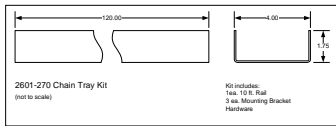
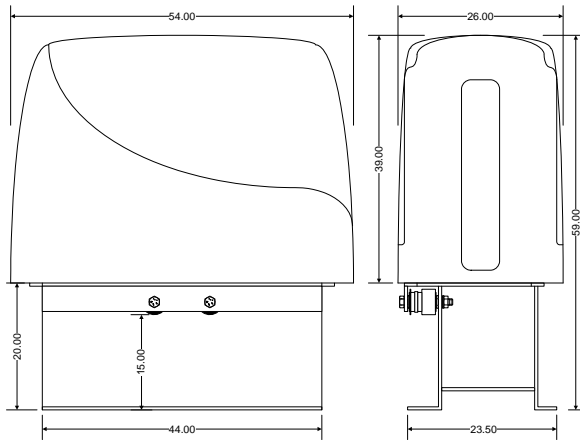

Operators

- 9530-080 3 HP, 208V 3^Ø 12,000.00
- 9530-081 3 HP, 230V 3^Ø 12,000.00

Accessories

- 2601-270 Chain Tray Kit 10-ft. 262.50
- 2601-268 10-ft #80 chain 93.00
- 2601-269 20-ft #80 chain 186.00
- Slide gate accessories Sec 1, Pg 14-16
- Secondary entrapment prevention devices Sec 1, Pg 18
- Loops and loop detectors Sec 1, Pg 19
- Gate operator control stations Sec 1, Pg 20
- Postal & Fire Dept Lock Boxes Sec 1, Pg 21
- Time Clocks & Surge Suppression Sec 1, Pg 22

9530 Maximum Capacities				
Model	Maximum Speed	Chain	Max Gate Weight (lbs.)	Max Gate Width (ft.)
9530	2 ft/sec	80	10,000	160

Model 9550

Slide Gate Operators

9550 Series Variable Speed operators feature slow-start / slow-stop operation. These operators are designed to operate very large and very heavy vehicular sliding gates (up to 20,000 Lbs) used in Limited (Class III) and Restricted (Class IV) industrial and maximum security applications. These operators have a full feature circuit board and come with #100 chain. Chain support tray (p/n 2601-270) should be used on gates exceeding 20 feet in length.

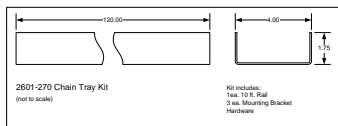
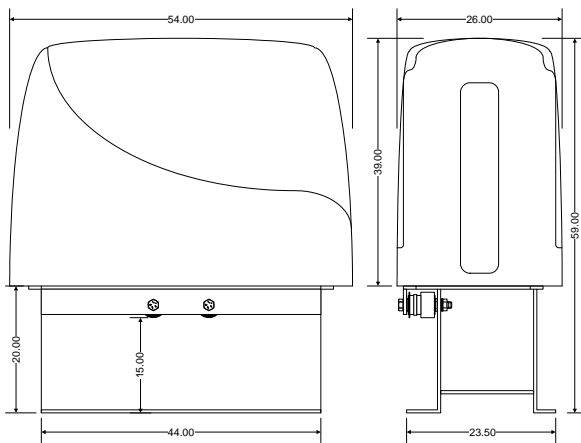

Operators

9550-080 5 HP, 208V 3 ^Ø	21,480.00
9550-081 5 HP, 230V 3 ^Ø	21,480.00

Accessories

2601-270 Chain Tray Kit 10-ft.	262.50
2600-xxx #100 chain	open
Slide gate accessories	Sec 1, Pg 14-16
Secondary entrapment prevention devices	Sec 1, Pg 18
Loops and loop detectors	Sec 1, Pg 19
Gate operator control stations	Sec 1, Pg 20
Postal & Fire Dept Lock Boxes.....	Sec 1, Pg 21
Time Clocks & Surge Suppression	Sec 1, Pg 22

9550 Maximum Capacities				
Model	Maximum Speed	Chain	Max Gate Weight (lbs.)	Max Gate Width (ft.)
9550	2 ft/sec	100	20,000	160

Model 9555

Slide Gate Operators

9550 Series Variable Speed operators feature slow-start / slow-stop operation and gate speeds of up to 4-Ft/sec. These operators are designed to operate very large and very heavy vehicular sliding gates used in Limited (Class III) and Restricted (Class IV) industrial and maximum security applications that have a need for a high speed gate. These operators have a full feature circuit board and come with #80 chain. Chain support tray (p/n 2601-270) should be used on gates exceeding 20 feet in length.

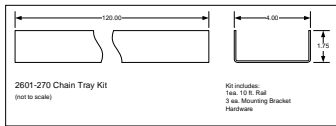
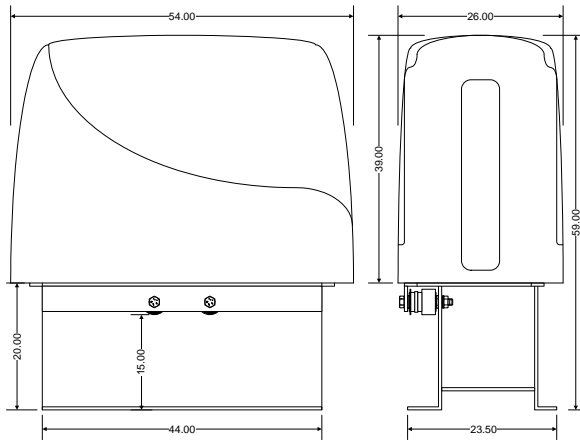

Operators

- 9555-080 5 HP, 208V 3^Ø 14,700.00
- 9555-081 5 HP, 230V 3^Ø 14,700.00

Accessories

- 2601-270 Chain Tray Kit 10-ft. 262.50
- 2601-268 10-ft #80 chain 93.00
- 2601-269 20-ft #80 chain 186.00
- Slide gate accessories Sec 1, Pg 14-16
- Secondary entrapment prevention devices Sec 1, Pg 18
- Loops and loop detectors..... Sec 1, Pg 19
- Gate operator control stations Sec 1, Pg 20
- Postal & Fire Dept Lock Boxes Sec 1, Pg 21
- Time Clocks & Surge Suppression Sec 1, Pg 22

9555 Maximum Capacities				
Model	Maximum Speed	Chain	Max Gate Weight (lbs.)	Max Gate Width (ft.)
9555	4 ft/sec	80	10,000	160

Slide Gate Operator Parts & Accessories

Miscellaneous Parts & Accessories

Circuit Boards

4404-010397.50
Used in models 9210, 9220, 9230, 9235, 9530, 9550, 9555

Accessories

2600-485 #50 Chain – 20 Ft 127.50
2600-448 #60 Chain – 20 Ft 142.50
2601-268 #80 Chain – 10 Ft 93.00
2601-269 #80 Chain – 20 Ft 186.00
2600-xxx #100 Chain – 20 Ft open
2600-284 Chain Stop for #60 Chain 15.00
1601-195 Heater 115 VAC..... 420.00
1601-197 Heater 208/230 VAC 420.00

