

Section 3

Parking Control Products

Operators

Model 1150 Overhead Gate Operator	2
Model 1601 Barrier Gate Operator	3
Model 1602 Barrier Gate Operator	4
Model 1603 Barrier / Auto-Spike Operator	5

Traffic Control

Stand-Alone Traffic Spikes, Speed Bumps	6
Warning Signs, Traffic Signals	7

Secondary & Vehicular Reversing Devices

Secondary Entrapment Protection Devices Type B1 and B2	8
Loop Detectors and Loops	9

Accessories

Manual Control / Lock Boxes	10
Time Clocks, Surge Suppressers, Traffic Signal	11
Accessory Transformers	12
Replacement Components	13

Back-up Power Inverters

Model 1000 / 2000	14
-------------------------	----

Model 1150

Overhead Gate Operator

The Model 1150 is designed to operate overhead type vehicular gates that are mounted on jamb track or jamb type hardware. The low profile and quiet operation of the 1150 make it ideal for underground parking control applications.

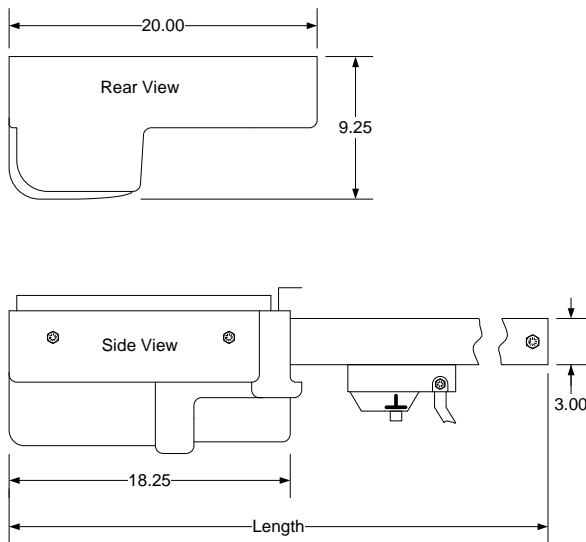

Step 1: Choose Power Head

1150-080 1/2 HP, 115V1810.00

Step 2: Choose a Rail Assembly

1150-225 (8-Ft high gates) 330.00

1150-226 (10-Ft high gates) 490.00

1150-227 (12-Ft high gates) 640.00

1150-228 (14-Ft high gates) 800.00

Accessories

Secondary entrapment prevention devices Pg 8

Loops and loop detectors Pg 9

Manual control / lock boxes Pg 10

Accessories Pg 11

Model 1150 Maximum Capacities			
Rail Part Number	Overall Length (ft.)	Max Gate Height (ft.)	Cycles (day)
1150-225	11	8	Cont.
1150-226	13	10	Cont.
1150-227	15	12	Cont.
1150-228	17	14	Cont.

Model 1601

Barrier Gate Operator

The Model 1601 is designed for high usage vehicle control applications in traffic lanes up to 14-feet wide. The arm will rotate to the full up position in approximately 1.5 seconds.

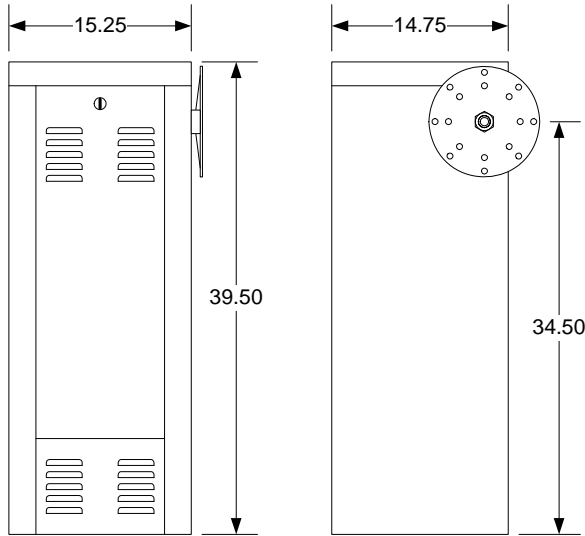

Step 1: Choose an Operator

1601-080 1/2 HP, 115 V	2760.00
1601-087 1/2 HP, 230 V	3190.00
1601-089 1/2 HP, 460 V	3190.00
1601-081 1/2 HP, 115 V w/C.O.	3580.00
1601-088 1/2 HP, 230 V w/C.O.	4010.00
1601-090 1/2 HP, 460 V w/C.O.	4010.00

- C.O. = Convenience Open which raises arm upon AC power loss
- 208 / 230 / 460 Volt operators use a step-down transformer to achieve 115 Volt operating voltage

Step 2: Choose a Hardware Kit

1601-240 Wood Arm Hardware Kit.....	120.00
1601-241 Plastic Arm Hardware Kit	120.00
1601-242 Aluminum Arm Hardware Kit.....	150.00

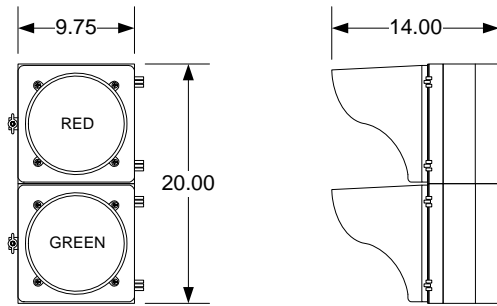

1603-208

Step 3: Choose an Arm

1601-048 Wood Arm 14-Ft	88.00
1601-084 Folding Wood Arm.....	314.00
1601-071 Plastic Arm 12-Ft.....	54.00
1601-083 Folding Plastic Arm	314.00
1601-216 Aluminum Arm 14-Ft.....	216.00
1601-310 Folding Aluminum Arm	390.00

Accessories

1603-208 Traffic Signal	704.00
1601-092 Heater Kit.....	216.00
1601-093 Fan Kit.....	216.00
1601-260 Foam Padding for Aluminum/Wood Arm	65.00
1601-270 Manual Crank Kit.....	230.00
Secondary entrapment prevention devices	Pg 8
Loops and loop detectors.....	Pg 9
Manual control / lock boxes.....	Pg 10
Accessories	Pg 11

Model 1601 Arm Options			
Arm Type	Max Arm Length (ft.)	Style	Folding Option
Plastic	12	2.5 x 2.5 in. Square	Yes
Wood	14	.75 x 3.25 in. Rectangular	Yes
Aluminum	14	3 in. Round	Yes

Model 1602

Barrier Gate Operator

The Model 1602 is designed for low usage vehicle control applications in traffic lanes up to 20-feet wide. The 3-piece wishbone style arm will rotate to the full up position in approximately 5.5 seconds.

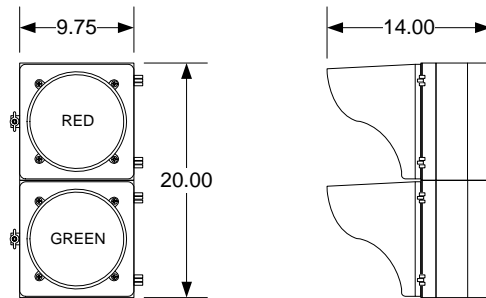
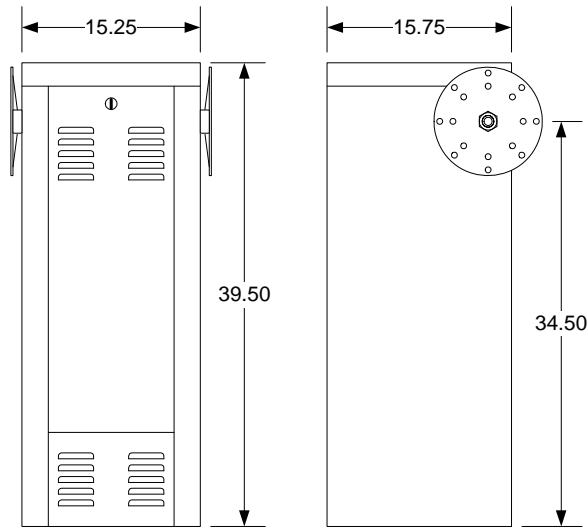

1603-208

Step 1: Choose an Operator

1602-080 1 HP, 115 V	3890.00
1602-082 1 HP, 230 V	4320.00
1602-084 1 HP, 460 V	4320.00
1602-081 1 HP, 115 V w/C.O.....	4710.00
1602-083 1 HP, 230 V w/C.O.....	5140.00
1602-085 1 HP, 460 V w/C.O.....	5140.00

- C.O. = Convenience Open which raises arm upon AC power loss
- 208 / 230 / 460 Volt operators use a step-down transformer to achieve 115 Volt operating voltage

Step 2: Choose an Arm

1602-040 3-Piece, 20-Ft Wood	324.00
1602-150 3-Piece, 28-Ft Aluminum	3190.00
1602-xxx 3-Piece, 20-Ft Aluminum	open
1602-xxx 3-Piece, 24-Ft Aluminum	open

Accessories

1603-210 Traffic Signal & Mount Kit.....	864.00
1601-092 Heater Kit.....	216.00
1601-093 Fan Kit.....	216.00
1601-260 Foam Padding for Aluminum/Wood Arm	65.00
1601-270 Manual Crank Kit	230.00
Secondary entrapment prevention devices	Pg 8
Loops and loop detectors	Pg 9
Manual control / lock boxes	Pg 10
Accessories	Pg 11

Model 1602 Arm Options			
Arm Type	Max Arm Length (ft.)	Style	Length Options
Wood	20	3-piece Wishbone .75 x 3.25 in. Rectangular	No
Aluminum	28	3-piece Wishbone 3 in. Round	20 ft. 24 ft. 28 ft.

Model 1603

Barrier Gate Operator / Auto-Spike System

The Model 1603 is designed to mechanically link traffic control auto-spikes to the operator arm. Warning sign and/or traffic signal **MUST** be used with this operator.

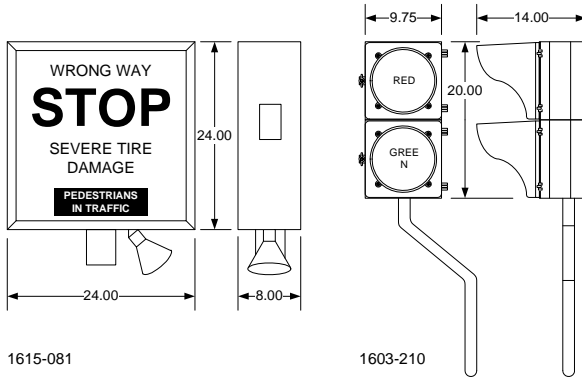
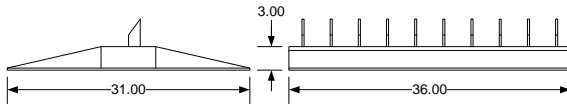
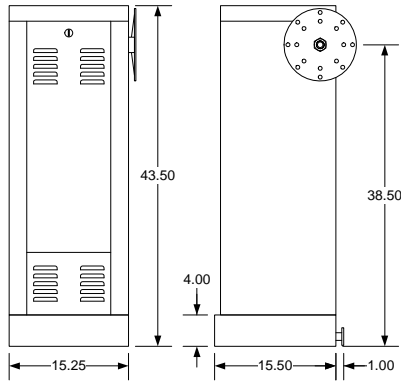

Choose an Operator

- 1603-080 1/2 HP, 115 V 3890.00
 - 1603-082 1/2 HP, 230 V 4320.00
 - 1603-084 1/2 HP, 460 V 4320.00

 - 1603-081 1/2 HP, 115 V w/C.O. 4710.00
 - 1603-083 1/2 HP, 230 V w/C.O. 5140.00
 - 1603-085 1/2 HP, 460 V w/C.O. 5140.00
- C.O. = Convenience Open which raises arm upon AC power loss
 - 208 / 230 / 460 Volt operators use a step-down transformer to achieve 115 Volt operating voltage

Step 2: Choose a Hardware Kit

- 1601-240 Wood Arm Hardware Kit..... 120.00
- 1601-242 Aluminum Arm Hardware Kit..... 150.00

Step 3: Choose an Arm

- 1601-048 Wood Arm 14-Ft 88.00
- 1601-216 Aluminum Arm 14-Ft..... 216.00

Step 4: Select Spike Components

- 1603-073 Spike Section 3-Ft..... 1620.00
 - 1603-076 Spike Section 6-Ft..... 3240.00
 - 1603-192 Tunnel Section 2-Ft 864.00
 - 1603-193 Tunnel Section 3-Ft 1300.00
 - 1603-118 End Cap 324.00
 - 1603-069 Spike Connector 54.00
- Spike connector required to connect spike sections together

Accessories

- 1615-081 Warning Sign..... 970.00
- 1603-210 Traffic Signal & Mount Kit 864.00
- 1601-092 Heater Kit..... 216.00
- 1601-093 Fan Kit..... 216.00
- 1601-260 Foam Padding for Aluminum/Wood Arm 65.00
- 1601-270 Manual Crank Kit..... 230.00
- Secondary entrapment prevention devices Pg 8
- Loops and loop detectors..... Pg 9

Model 1603 Arm Options			
Arm Type	Max Arm Length (ft.)	Style	Folding Option
Wood	14	.75 x 3.25 in. Rectangular	Yes
Aluminum	14	3 in. Round	Yes

Model 1610

Stand-Alone Traffic Control Spikes

These traffic control products are ideal for controlling traffic direction and speed through a controlled entry location. Traffic spikes are used to enforce one-way traffic and speed bumps force vehicles to slow down as they pass through the controlled area. **A warning sign (see page 7) must be used with the traffic spikes.**

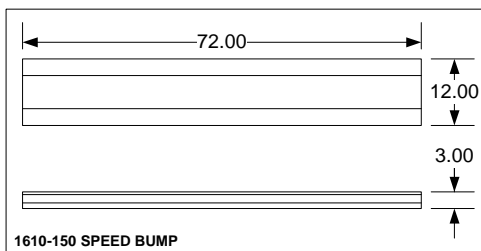
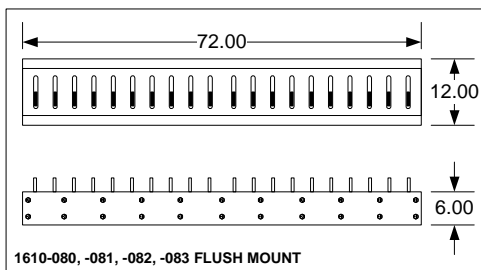
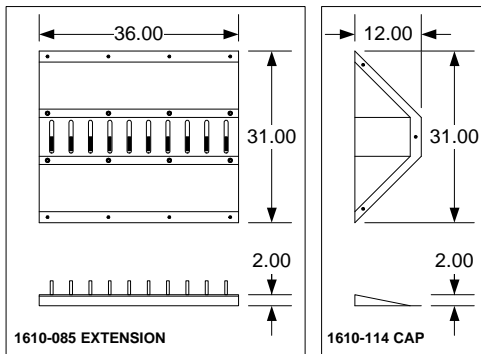
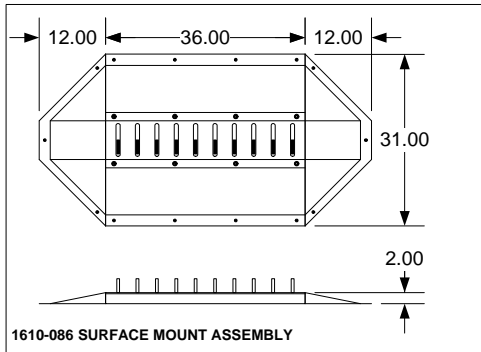

Surface Mount Traffic Spikes – 3 Foot

1610-086 Assembly.....	2328.00
1610-085 Extension 3 ft.	1680.00
1610-114 End Cap.....	360.00
1610-010 Lock Down Tool	65.00

- These traffic spikes use spring retraction and have a lock-down feature (requires lock down tool)
- 1610-086 assembly includes one (1) 1610-085 and two (2) 1610-114

Flush (In-Ground) Traffic Spikes – 6 Foot

1610-080 Spring Retraction	1290.00
1610-081 Weighted Retraction.....	1290.00
1610-082 Spring Retraction w/ Lock Down.....	1500.00
1610-083 Weighted Retraction w/ Lock Down	1500.00
1610-012 Lock Down Tool / Spring Retraction.....	65.00
1610-013 Lock Down Tool / Weighted Retraction	65.00

Speed Bump

1610-150.....	324.00
---------------	--------

Model 1610 Spike Options			
Type	Available Length	Spike Retraction	Lockdown
Surface Mount	3 ft. Section	Spring	Yes
Flush Mount	6 ft. Section	Spring or Weighted	Optional

Traffic Control

Warning Sign, Traffic Signal

The traffic control signal is ideal for use with parking control, slide and swing gate operators, or in any application that requires a visual signal regarding any traffic hazards. **The illuminated warning sign must be used with the traffic spikes.**

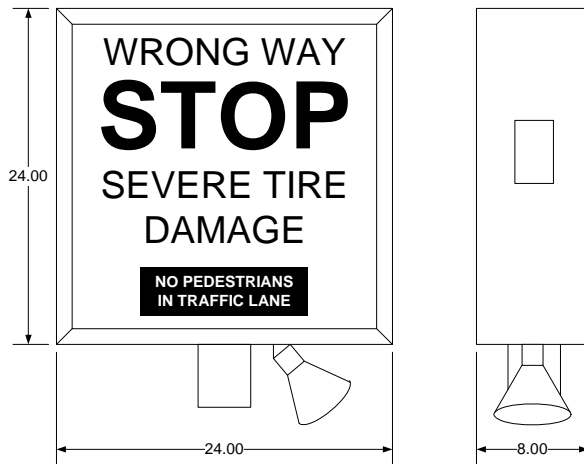

Warning Sign

- 1615-080 use/w Stand-Alone spike systems 970.00
- 1615-081 use w/1603 Auto-Spike system 970.00
- 1615-082 – Same as 1615-080 in Spanish 970.00

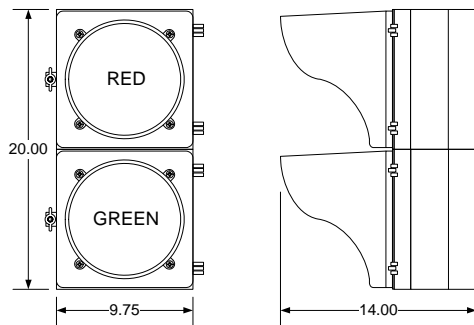

Traffic Signal

- 1603-208 Traffic Light 704.00
- 1603-210 Traffic Light w/Mount Post for 1603 864.00

Secondary Entrapment Prevention

Type B1 and Type B2

Secondary entrapment prevention devices are required in almost all general access automated gate applications. Photo-cells are used as type B1 (non-contact sensors) devices. Electric edges are used as type B2 (contact sensors) devices.

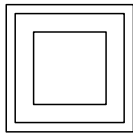

8080-010

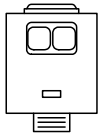
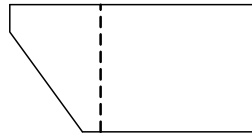

8080-011

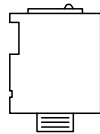

8080-030 / 8080-031

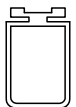
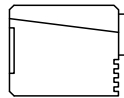

8080-016

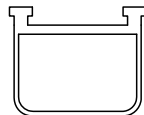

8080-015

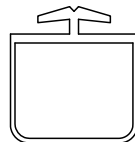

8080-020

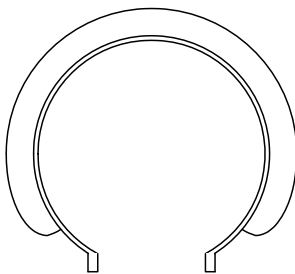

8080-021

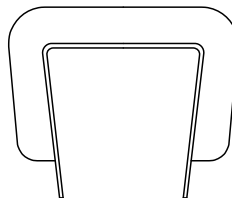

8080-022

Type B1 Non-Contact Sensors

8080-010 Infrared Thru-Beam 420.00

- 24 Volt AC / DC
- 165-foot maximum sensing distance
- Separate sender and receiver
- Includes hood and heated enclosure

8080-011 Photo Reflective..... 314.00

- 12 Volt DC / 24 Volt AC
- 30-foot maximum sensing distance

8080-030 Polarized Photo Reflective 292.00

- 24-240 Volt AC / 12-240 Volt DC
- 35-foot maximum sensing distance

8080-031 Infrared Thru-Beam 390.00

- 24-240 Volt AC / 12-240 Volt DC
- 65-foot maximum sensing distance
- Separate sender and receiver

Type B2 Contact Sensors

8080-016 6-Foot Edge..... 205.50

- Includes mounting channel - ideal for barrier arms

8080-015 5-Foot Edge..... 205.50

- Includes mounting channel

8080-020 5-Foot Edge..... 249.00

- Sensitive on all 3 sides – includes mounting channel

8080-021 5-Foot Edge..... 260.00

- Designed to fit on 2-inch round gate post

8080-022 5-Foot Edge..... 260.00

- Designed to fit on 2-inch square gate post

Contact Sensor Accessories

8060-061 Wireless RF Kit 357.00

- Receiver (12-24 Volt AC/DC) and transmitter housed in NEMA 4 enclosure with low battery alarm

8080-017 Coiled Cord 16-Foot 61.00

8060-076 Plastic Receiver Box 17.50

Vehicle Protection

Loop Detectors and Loops

Loop detectors and loops are strongly recommended on all automated vehicular gate applications to help prevent gates from closing on vehicles in the path of the gate. These devices are not considered to be secondary entrapment prevention devices.

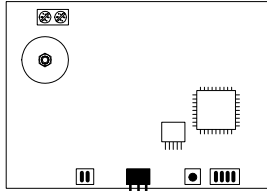

9410-010

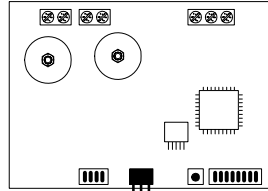

9409-010

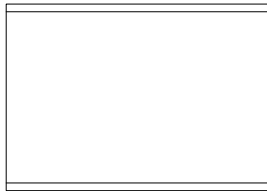

9402-045 / 9402-047

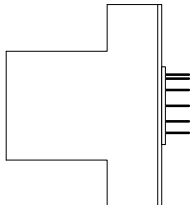
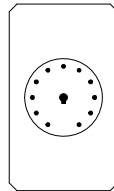

9402-044

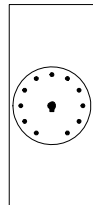

Loop Detectors

9410-010 DKS Single Channel 199.50

- Plug-in detector - use with DKS gate operators only

9409-010 DKS Two Channel 378.00

- Plug-in detector – use with DKS gate operators only

9402-045 Reno A&E 12/24 Volt DC or 24 Volt AC 250.00

9502-047 Reno A&E 120 Volt AC 250.00

- Reno A&E detectors have 2 relay outputs
- Reno A&E detectors require 9402-061 wire harness

9402-044 Carlo Gavazzi 24 Volt AC or DC 185.50

- Carlo Gavazzi detector - 2 relay outputs
- Requires 9402-061 wire harness

9402-061 Wire Harness..... 22.00

Loop Wire – 18 AWG – XLPE Insulation

9402-076 500-Ft Roll – Black..... 150.00

9402-077 1000-Ft Roll – Black..... 240.00

9402-078 500-Ft Roll – Blue 150.00

9402-079 1000-Ft Roll – Blue 240.00

9402-080 500-Ft Roll – Red..... 150.00

9402-081 1000-Ft Roll – Red 240.00

Prefabricated Loops, 24-Ft Circumference, 50-Ft Lead-In

9401-060 Blue Loop Wire / PLIOVIC Tubing 160.00

9401-061 Yellow Loop Wire / PLIOVIC Tubing 160.00

9401-062 Red Loop Wire / PLIOVIC Tubing 160.00

Loop Miscellaneous

2600-771 Asphalt Sealant (Black) – 10 oz. Tube 11.00

2600-772 Concrete Sealant (Gray) – 10 oz. Tube..... 11.00

9401-045 Loop Test Meg-Ohm Meter..... 450.00

Manual Control / Lock Boxes

Postal and Fire Department

The 1200-017 control station is used when barrier gate operators will be manually controlled. Postal and Fire Department lock boxes provide a method for these authorities to gain access through a vehicular access gate.

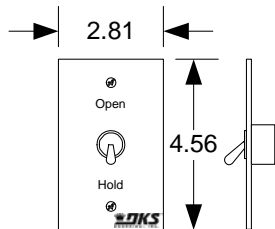

1200-017

1200-017..... 43.50

- Open-hold-normal gate control
- Mounts into single-gang electric box

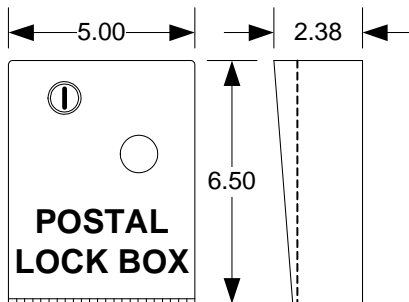

1402-080

1402-080..... 99.50

- Accepts standard postal key lock
- Postal lock can be installed to either open the 1402 box, or activate a door or gate
- Surface or post mount
- Painted postal blue

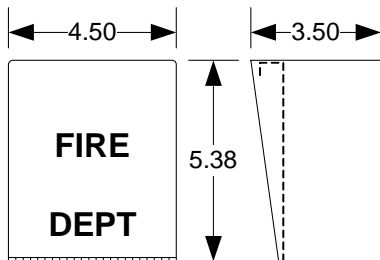

1400-080

1400-080..... 99.50

- Accepts Fire Department pad lock
- Cover opens and activates a switch when the pad lock is removed
- Gate or door will hold open until the cover is closed and the pad lock replaced
- Surface or post mount
- Painted bright red

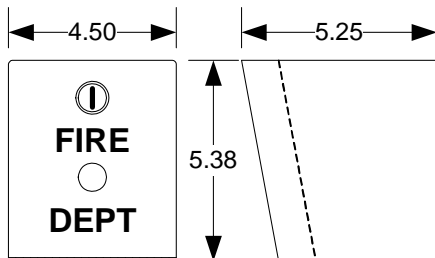

1401-080

1401-080..... 99.50

- Accepts Knox 3501 key switch
- Surface or post mount
- Faceplate painted bright red, box is painted black

Accessories

Time Clock & Surge Suppressers

Electronic time clocks are ideal for use in applications where an access control system does not control “hold open” time periods. Vehicular gate operators and barrier gate operator systems are typical. Surge suppressers are designed to provide additional protection to equipment in areas prone to voltage spikes and surges. Surge suppressers come with a plastic mounting bracket. Red / Green traffic signal is ideal for all vehicular gate applications – providing a visual signal when the gate is safe to drive through.

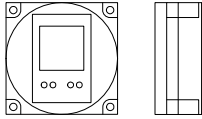

2600-791

2600-791..... 205.50

- 7 Day Time Clock
- 20 programs
- 24 Volt AC input power
- Form “C” dry contact relay

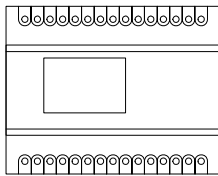

2600-795

2600-795..... 640.00

- 365 Day Time Clock
- 7-Day and 24 hour programming features
- Holiday programming
- Automatic leap-year adjustment through 2095
- Daylight savings time
- 24 Volt AC input power

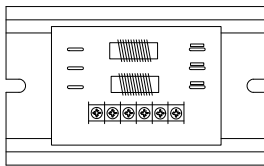
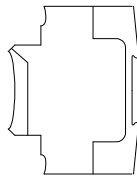

1876-010 / 1878-010

1876-010..... 124.00

- High Voltage (110-120 VAC)

1878-010..... 124.00

- Low Voltage (24-20 VAC)

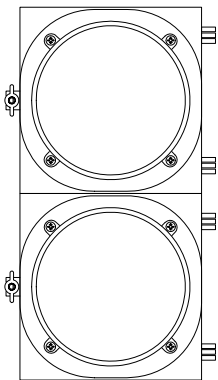

1603-208

1603-208..... 704.00

- Red / Green traffic signal
- 8-inch lens

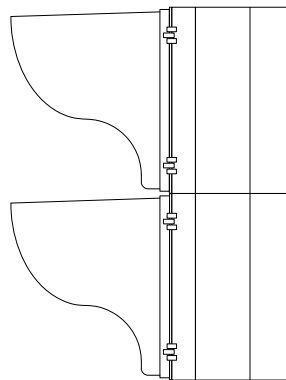

Accessory Transformers

12, 16, 24 Volt AC & DC Transformers

A variety of accessory transformers are available to power the different products that we sell. AC transformers are typically used with access control devices and controllers, while DC transformers are used with magnetic locks and proximity card readers. Check the individual product to determine which transformer is required. NOTE: Many of our products INCLUDE a transformer.

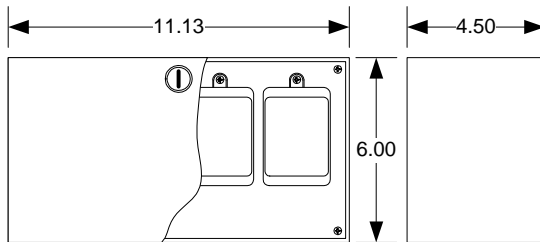

1200-080

Transformer Box

1200-080..... 130.00

- Holds up to four (4) 20-VA transformers
- Suitable for indoor and outdoor use
- Does not include transformers

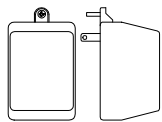

20 VA Transformers

1215-061 12-Volt AC Output
1804-059 24-Volt AC Output
1804-060 16-Volt AC Output

20-VA Transformers

1215-061 12-Volt, AC..... 37.50
1804-059 24-Volt, AC..... 43.50
1804-060 16-Volt, AC..... 43.50

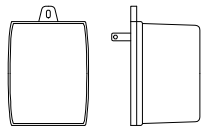

50 VA Transformer

1508-060 16-Volt AC Output

50-VA Transformer

1508-060 16-Volt, AC..... 48.00

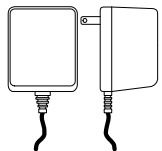

DC Transformers

1215-060 24-Volt 350 mA
1812-035 24-Volt 500 mA
1812-037 12-Volt 1000 mA

DC Transformers

1215-060 24-Volt, 350 ma 43.50
1812-035 24-Volt, 500 ma 32.50
1812-037 12-Volt, 1000 ma 39.00

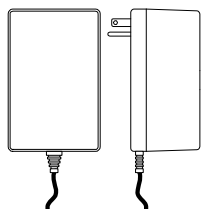

Regulated DC Transformer

1812-038 12-Volt 1000 mA

DC Regulated Transformer

1812-038 12-Volt, 1000 ma 97.50

Operator Parts & Replacement Items

Miscellaneous Parts & Accessories

Circuit Boards	
1601-010.....	530.00
Used in models 1601, 1602 and 1603	
4402-010.....	530.00
Used in model 1150	
2340-010.....	220.00
Used in models 1150, 1601, 1602 and 1603 with convenience open option	

Barrier Operator Replacement Parts	
1601-069.....	33.00
Wood arm mounting bracket	
1601-068.....	33.00
Plastic arm mounting bracket	
1601-202.....	65.00
Aluminum arm mounting bracket	
1601-079.....	76.00
Arm mounting hub	
1801-009.....	76.00
12 Volt, 3 AH replacement battery	

Traffic Control Replacement Components	
1615-032.....	114.00
Warning sign replacement panel - RED	
1615-034.....	114.00
Warning sign replacement panel - GREEN	
1615-035.....	114.00
Auto-spike warning sign replacement panel – RED	
1610-030.....	26.00
Replacement spike for 1610-080 spike set	
1610-031.....	7.20
Replacement spring for 1610-080 spike set	

Models 1000 / 2000

Back-up Power / Inverters

The model 1000 and 2000 Power Inverters are designed to provide backup 120 VAC power for gate operators and access control systems when primary (AC) power fails. The model 1000 is designed to provide power for two (2) gate operators and related access control system accessories while the model 2000 can provide power for up to six (6) gate operators and related access control accessories.

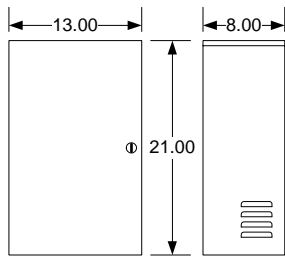

Model 1000

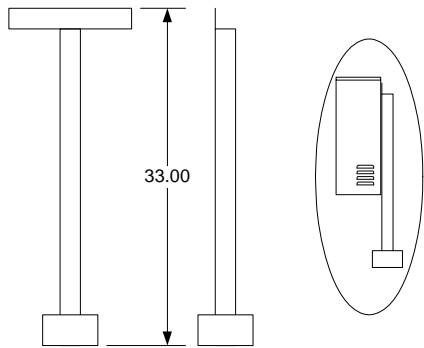

1000-045

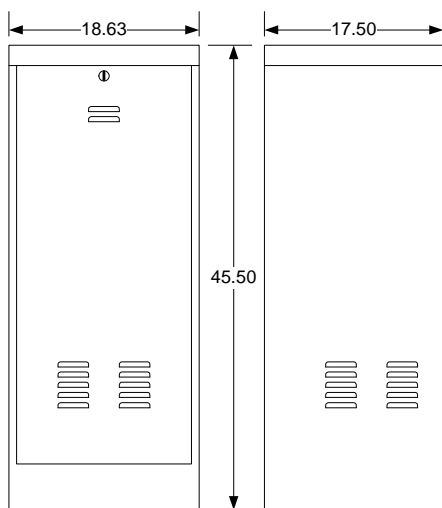

Model 2000

Model 1000 Inverter

1000-080 1000 Watt, 9.0 Amp Maximum.....	1300.00
1000-081 1500 Watt, 12.5 Amp Maximum.....	1700.00

- The 1000 Watt inverter includes one (1) battery and will power one (1) 1/2 HP operator
- The 1500 Watt inverter includes two (2) batteries and will power two (2) 1/2 HP operators or one (1) 1 HP operator

1000-045 Post Mount for 1000 Inverter	130.00
---	--------

1000-048 Battery & Cable Assembly.....	120.00
--	--------

- Order this to add a second battery to the 1000 Watt inverter
- | | |
|------------------------|--------|
| 1000-044 Battery | 100.00 |
|------------------------|--------|
- 12 Volt, 35 AH SLA (Sealed Lead Acid) battery

Model 2000 Inverter

2000-080 1500 Watt, 12.5 Amp Maximum.....	6050.00
2000-081 2400 Watt, 20 Amp Maximum.....	6490.00
2000-082 3600 Watt, 30 Amp Maximum.....	6920.00

- Model 2000 inverters can power up to six (6) gate operators
- Model 2000 inverters require two (2) 12 Volt Deep Cycle batteries connected in series to provide a 24 Volt DC input to the inverter system
- Model 2000 inverters DO NOT include batteries

