



Owner's Manual

***Model 9530
Vehicular Slide Gate Operator***

DoorKing, Inc.
120 Glasgow Avenue
Inglewood, California 90301
U.S.A.
Phone: 310-645-0023
Fax: 310-641-1586
www.doorking.com

Use this manual with the following models only.

Models 9530-080, 9530-081 with circuit board 4404-010.

DoorKing, Inc. reserves the right to make changes in the products described in this manual without notice and without obligation of DoorKing, Inc. to notify any persons of any such revisions or changes. Additionally, DoorKing, Inc. makes no representations or warranties with respect to this manual. This manual is copyrighted, all rights reserved. No portion of this manual may be copied, reproduced, translated, or reduced to any electronic medium without prior written consent from DoorKing, Inc.

TABLE OF CONTENTS

Important Notices.....	6
Important Safety Instructions.....	7
Restrictions and Warnings.....	8
Entrapment Prevention.....	9
Glossary	10

Section 1 – Installation

1.1	Specifications	11
1.2	Mounting Options	12
1.3	Chain Guide Adjustment.....	13
1.4	Pad Mount Installation	14
1.5	Mounting Stand Installation	16
1.6	Chain Installation	18
1.7	Warning Sign Installation.....	20

Section 2 – Wiring

	Conduits	21
2.1	High Voltage Connections.....	22
2.2	Control Wiring.....	23
	2.2.1 High Speed Emergency Close	24
2.3	Secondary Entrapment Protection Device Wiring	
	2.3.1 Non-Contact Sensors	25
	2.3.2 Contact Sensors.....	26
2.4	Loop Detector Wiring.....	27
2.5	Gate Tracker™ Connections	28
2.6	Auxiliary Devices	
	2.6.1 Alarm Reset Switch	29
	2.6.2 Auxiliary Stop Switch.....	29
2.7	Primary / Secondary Wiring	
	2.7.1 Operator Interface	30
	2.7.2 Secondary Entrapment Protection Device Wiring	31
2.8	Terminal Identification and Description	
	2.8.1 Main Terminals.....	32
	2.8.2 Limit Switch Connector.....	33
	2.8.3 Reversing Device Connector.....	33

Section 3 – Adjustments

3.1	Circuit Board Adjustments	35
3.2	Switch Settings	36
	3.2.1 SW 1 (Right Switch) Description and Function	37
	3.2.2 SW 2 (Left Switch) Description and Function.....	37
3.3	Limit Switch Adjustment	
	3.3.1 Limit Switch Adjustment	38
	3.3.2 Slow-Down Switch Adjustment.....	39
3.4	Current Sensor Adjustment	40
3.5	Speed Control.....	41
3.6	Current Sensor Wiring Information	41

Section 4 – Operating Instructions

4.1	Power and Reset Switches	43
4.2	Shutdown Conditions	
4.2.1	Soft Shutdown	44
4.2.2	Resetting a Soft Shutdown	44
4.2.3	Hard Shutdown	45
4.2.4	Resetting a Hard Shutdown	45
4.3	Manual Gate Operation	46

Section 5 – Maintenance and Troubleshooting

5.1	Maintenance Schedule	47
5.2	Operator Diagnostics	48
5.3	Troubleshooting	49
5.4	Accessories	51
Wire Diagrams		
	208 VAC, 3-Phase Variable Speed	52
	230 VAC, 3-Phase Variable Speed	53

IMPORTANT NOTICES

Vehicular gate systems provide convenience to their users and limit vehicular traffic onto your property. These systems can produce high levels of force; therefore it is important that you are aware of possible hazards associated with your gate operating system. These hazards may include pinch points, entrapment, absence of controlled pedestrian access or traffic backup.

Be sure that the installer has instructed you on the proper operation of the gate and gate operator system. Be sure that the installer has trained you about the basic functions of the required reversing systems associated with your gate operating system and how to test them. These include reversing loops, inherent reversing system, electric edges, photoelectric cells, or other external devices.

- This Owner's Manual is your property. Keep it in a safe place for future reference.
- **Loops and loop detectors, photo-cells or other equivalent devices must be installed with this gate operator to prevent the gate from closing on vehicular traffic.**
- The speed limit for vehicular traffic through the gate area is 5 MPH. Install speed bumps and signs to keep vehicular traffic from speeding through the gate area. Failure to adhere to posted speed limits can result in damage to the gate, gate operator, and to the vehicle.
- Be sure that all residents are familiar with the proper use of the gate and gate operator. Be sure that all residents are familiar with the possible hazards associated with the gate system.
- Be sure that all warning signs are permanently installed on both sides of the gate in an area where they are fully visible to traffic.
- It is your responsibility to periodically check all reversing devices. If any of these devices are observed to function improperly, remove the operator from service immediately and contact your installing or servicing dealer.
- Follow the recommended maintenance schedule.
- Do not allow children to play in the area of the operator or to play with any gate-operating device.
- **Be sure that all activating devices are installed a minimum distance of 10 feet away from the gate and gate operator, or in such a way that a person cannot touch the gate or gate operator while using the activating device.** If activating devices are installed in violation of these restrictions, immediately remove the gate operator from service and contact your installing dealer.
- To remove the gate operator from service, operate the gate to the full open position and then shut off power to the operator at the service panel.

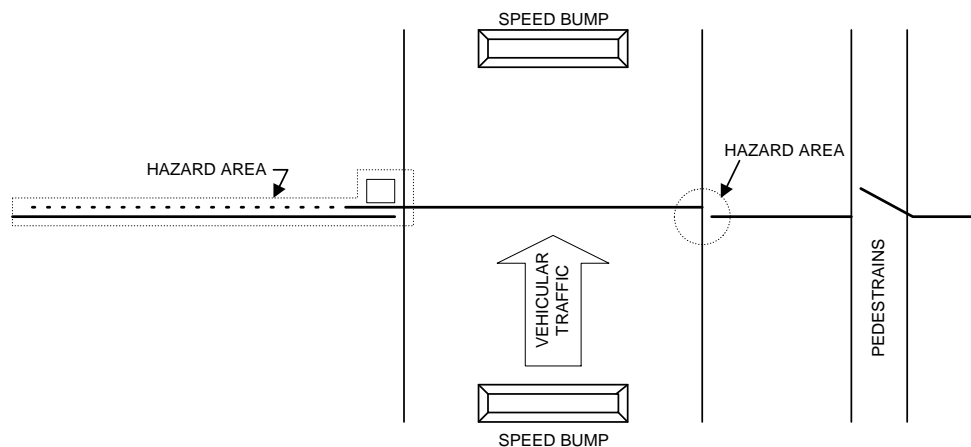

IMPORTANT SAFETY INSTRUCTIONS

WARNING - To reduce the risk of injury or death:

1. READ AND FOLLOW ALL INSTRUCTIONS.
2. Never let children operate or play with gate controls. Keep the remote control away from children.
3. Always keep people and objects away from gate. **NO ONE SHOULD CROSS THE PATH OF THE MOVING GATE.**
4. Test the operator monthly. The gate **MUST** reverse on contact (contact sensors must be installed) with a rigid object or stop or reverse when an object activates the non-contact sensors. After adjusting the force or the limit of travel, retest the gate operator. Failure to adjust and retest the gate operator properly can increase the risk of injury or death.
5. **KEEP GATES PROPERLY MAINTAINED.** Read the owner's manual. Have a qualified service person make repairs to gate hardware.
6. The entrance is for vehicles only. Pedestrians must use separate entrance.
7. **SAVE THESE INSTRUCTIONS!**

Gate Construction

Vehicular gates should be constructed and installed in accordance with **ASTM F2200; Standard Specification for Automated Vehicular Gate Construction**. For a copy of this standard, contact ASTM directly at 610-832-9585; service@astm.org; or www.astm.org.

RESTRICTIONS AND WARNINGS

Install the Gate Operator Only If:

- The operator is appropriate for the usage Class of the application and the gate is within the weight and length limitations specified for the operator.
- All openings of a horizontal slide gate are guarded or screened from the bottom of the gate to a minimum of 4 feet (1.2 m) above the ground to prevent a 2 1/4 inch (57.15 mm) diameter sphere from passing through the openings anywhere in the gate, and in that portion of the adjacent fence that the gate covers in the open position.
- All exposed pinch points are eliminated or guarded.
- This operator is intended for installation only on slide gates used to control vehicular traffic. Pedestrians must be provided with a separate access opening.
- The gate must be installed in a location so that sufficient clearance is provided between the gate and adjacent structures when opening and closing to reduce the risk of entrapment (see diagram). Sliding gates should not open into public access areas.
- The gate must be properly installed and work freely in both directions prior to the installation of the gate operator. Do not reduce reversing sensitivity to compensate for a damaged gate.
- Controls must be far enough from the gate so that the user is prevented from coming in contact with the gate while operating the controls. Outdoor or easily accessible controls should have a security feature to prevent unauthorized use.
- All warning signs and placards must be installed where visible in the area of the gate.

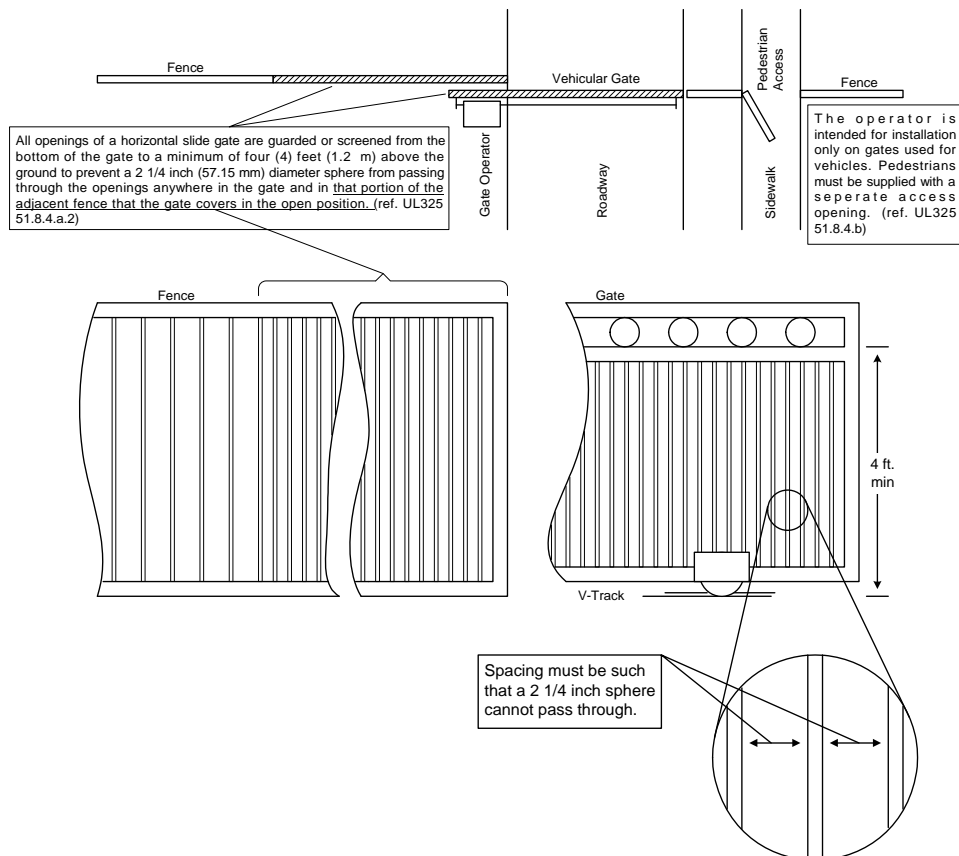

ENTRAPMENT PREVENTION

This vehicular gate operator must be installed with a non-contact (Type B1) and/or a contact (Type B2) entrapment sensing devices. This operator is not equipped with an inherent (Type A) sensing system.

Non-contact (Type B1) and/or contact (Type B2) sensors must be installed individually or in combination with each other to provide entrapment prevention. For gate operators utilizing a non-contact sensor:

- See diagram below for placement of non-contact sensors.
- Care should be exercised to reduce the risk of nuisance tripping, such as when a vehicle trips the sensor while the gate is still moving, and
- One or more non-contact sensors shall be located where the risk of entrapment or obstruction exists, such as the perimeter reachable by a moving gate or barrier.

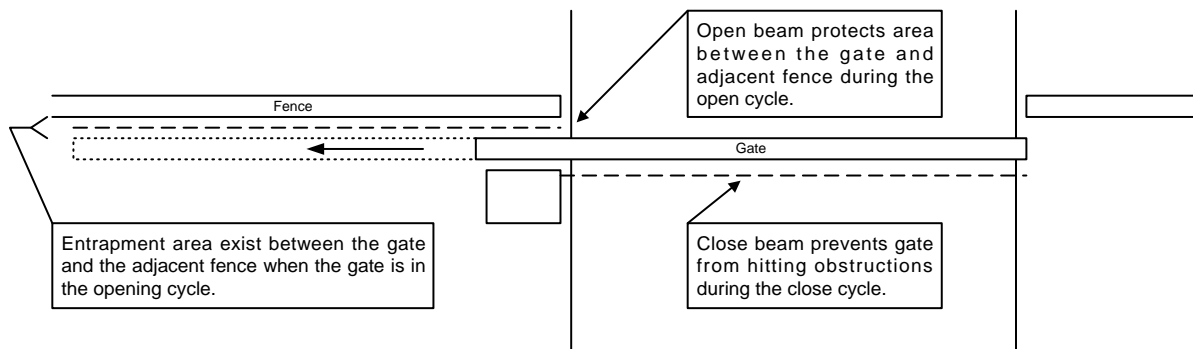

For gate operators utilizing a contact sensor:

- A hardwired contact sensor shall be located and its wiring arranged so that the communication between the sensor and the gate operator is not subjected to mechanical damage.
- A wireless contact sensor such as one that transmits radio frequency (RF) signals to the gate operator for entrapment prevention functions shall be located where the transmission of the signals are not obstructed or impeded by building structures, natural landscaping or similar obstruction. A wireless contact sensor shall function under the intended end-use conditions.

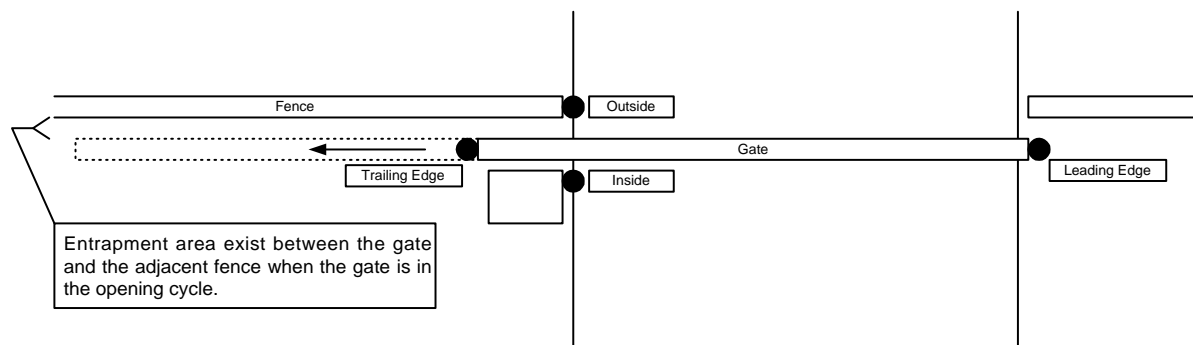

GLOSSARY

GATE – A moving barrier such as a swinging, sliding, raising, lowering, or the like, barrier, that is a stand-alone passage barrier or is that portion of a wall or fence system that controls entrance and/or egress by persons or vehicles and completes the perimeter of a defined area.

RESIDENTIAL VEHICULAR GATE OPERATOR-CLASS I - A vehicular gate operator (or system) intended for use in a home of one-to four single family dwelling, or garage or parking area associated therewith.

COMMERCIAL / GENERAL ACCESS VEHICULAR GATE OPERATOR-CLASS II - A vehicular gate operator (or system) intended for use in a commercial location or building such as a multi-family housing unit (five or more single family units), hotels, garages, retail store, or other building servicing the general public.

INDUSTRIAL / LIMITED ACCESS VEHICULAR GATE OPERATOR-CLASS III - A vehicular gate operator (or system) intended for use in an industrial location or building such as a factory or loading dock area or other locations not intended to service the general public.

RESTRICTED ACCESS VEHICULAR GATE OPERATOR-CLASS IV - A vehicular gate operator (or system) intended for use in a guarded industrial location or building such as an airport security area or other restricted access locations not servicing the general public, in which unauthorized access is prevented via supervision by security personnel.

SYSTEM - In the context of these requirements, a system refers to a group of interacting devices intended to perform a common function.

WIRED CONTROL - A control implemented in a form of fixed physical interconnections between the control, the associated devices, and an operator to perform predetermined functions in response to input signals.

WIRELESS CONTROL - A control implemented in means other than fixed physical interconnections (such as radio waves or infrared beams) between the control, the associated devices, and an operator to perform predetermined functions in response to input signals.

INHERENT ENTRAPMENT SENSOR SYSTEM - An automatic sensor system, which senses entrapment of a solid object and is incorporated as a permanent and integral part of the operator.

ENTRAPMENT – The condition when an object is caught or held in a position that increases the risk of injury.

SECTION 1 - INSTALLATION

Prior to beginning the installation of the slide gate operator, we suggest that you become familiar with the instructions, illustrations, and wiring guide-lines in this manual. This will help insure that your installation is performed in an efficient and professional manner. The proper installation of the vehicular slide gate operator is an extremely important and integral part of the overall access control system. Check all local building ordinances and building codes prior to installing this operator. Be sure your installation is in compliance with local codes.

1.1 SPECIFICATIONS

Class of Operation:	Class III, IV
Type of Gate:	Vehicular Slide Gates Only
Horsepower:	3 HP
Voltage / Phase:	208, 230 VAC 3 ϕ
Current:	12.4 A @ 208/230V
Max Gate Wt. ¹	5000 Lbs.
Max Gate Length:	100 Feet
Cycles / Hr:	60/Hr
Speed:	Normal mode adjustable ½ - 2 Ft./Sec. Panic close adjustable up to 6 Ft./Sec.
Entrapment Protection:	Provision for connection of a non-contact sensor (Type B1) and/or a contact sensor (Type B2). Secondary entrapment protection devices are not supplied with the operator and must be ordered separately.
Note 1:	Assumes gate is in good working condition installed on a level surface.

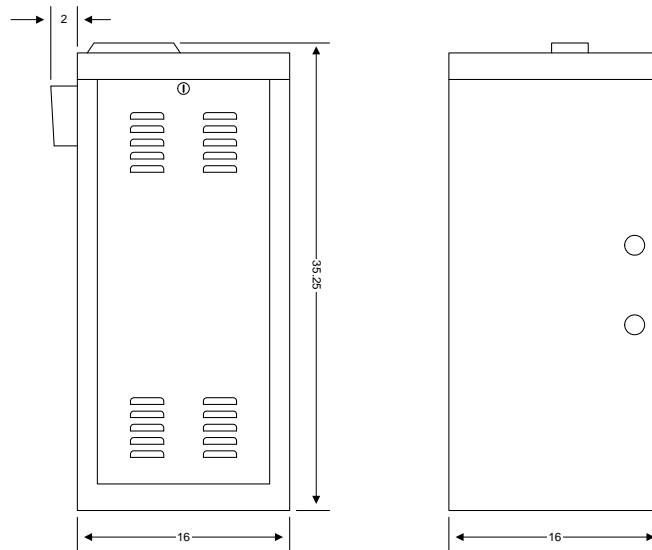

1.2 MOUNTING OPTIONS

The 9530 vehicular gate operator is designed to be mounted on the optional mounting stand (p/n 9200-135) or directly to a concrete pad. The mounting stand option is recommended if the gate length exceeds 30 feet since this mounting method will allow a "chain rest" to be mounted on the gate.

- Pad mounting is typically used with gates that are less than 30 feet in length.
- Requires use of the pad mounting plate that is included with the operator.

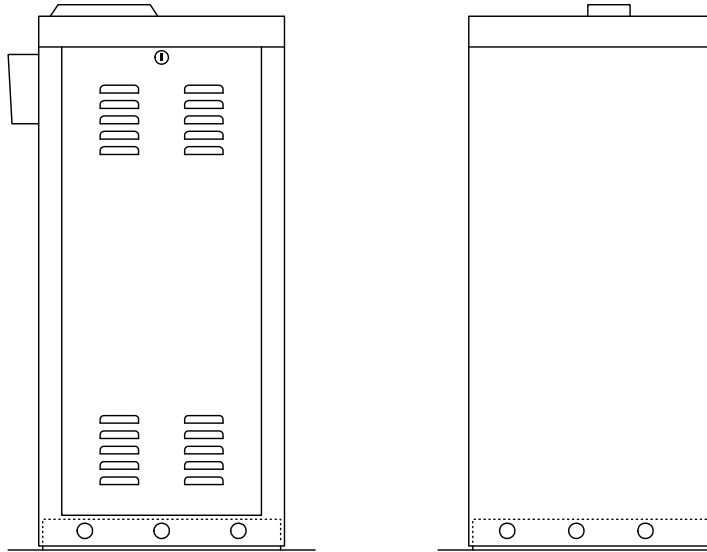

- Pedestal mounting is typically used with gates that are greater than 30 feet in length since this method allows a chain rest to be installed on the gate.
- Requires use of the pad mounting plate that is included with the operator.
- Requires use of the OPTIONAL operator mounting stand.

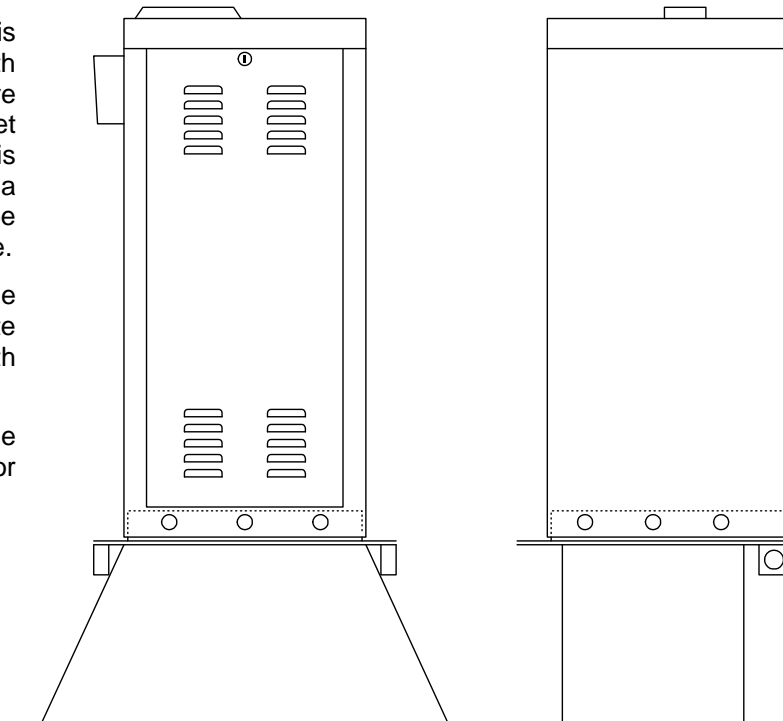

1.3 CHAIN GUIDE ADJUSTMENT

After determining which mounting method is to be used (pad or mounting stand), adjust the chain guides according to the mounting method being used.

- To gain access to the inside of the operator, remove three hex-head nuts from the left side of the control panel housing.
- Pull the housing out and away.

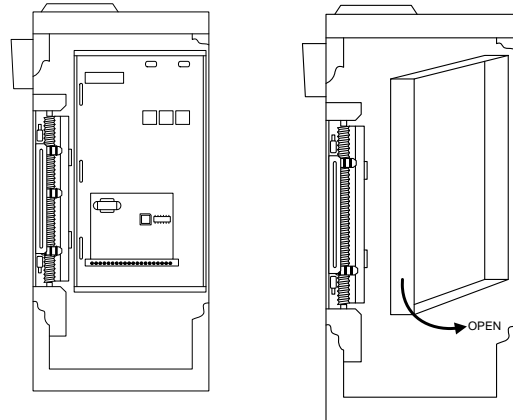

- For pad mounted operators, remove the UPPER hole knockouts from each side of the operator.
- Adjust the chain guides as shown.
- Chain will be routed OVER the chain guides and UNDER the drive sprocket.

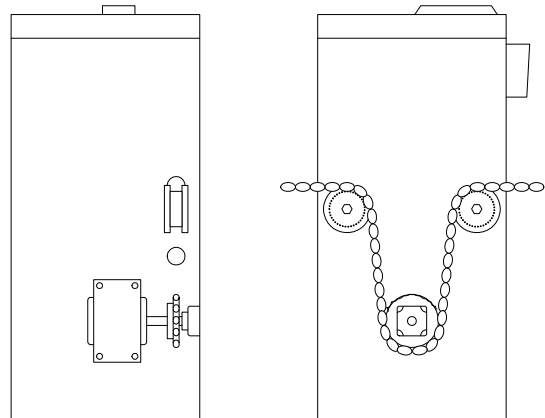

- For operators mounted on the mounting stand, DO NOT remove any hole knockouts.
- Adjust the chain guides as shown.
- Chain will be routed UNDER the chain guides and OVER the drive sprocket.

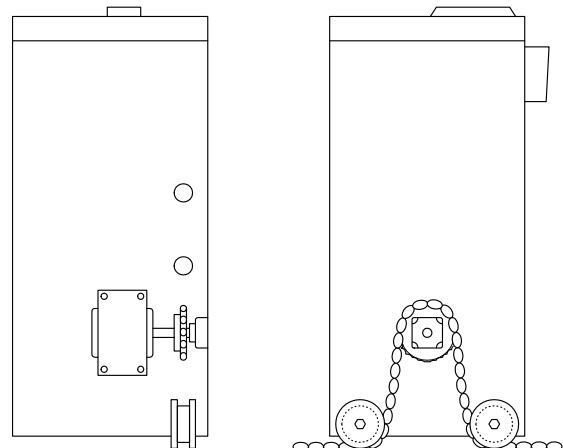

3. Mix the concrete according to the manufacturers instructions. Pour the mixture into the form and tamp. Level and finish the surface after pouring is complete. **Do not set anchor bolts in the concrete.** Sleeve anchors should be used to secure the operator to the pad. This allows greater flexibility in positioning the operator on the pad.
4. Allow the pad to cure for 48 hours before removing the forms or mounting the operator.
5. Once the pad has cured, place the operator / mounting plate on the pad in the proper position; 4-inches from the front and sides of the pad and 1-inch from the rear of the pad. **The operator mounting plate must be parallel to the gate.** **CAUTION: the operator is heavy. Two persons are required to lift the operator onto the mounting pad.**
6. Once the operator is in the proper position on the pad, secure the operator mounting plate directly to the pad using 3/8 or 1/2 x 3 sleeve anchors. **Be sure that the operator mounting plate is parallel to the gate.**

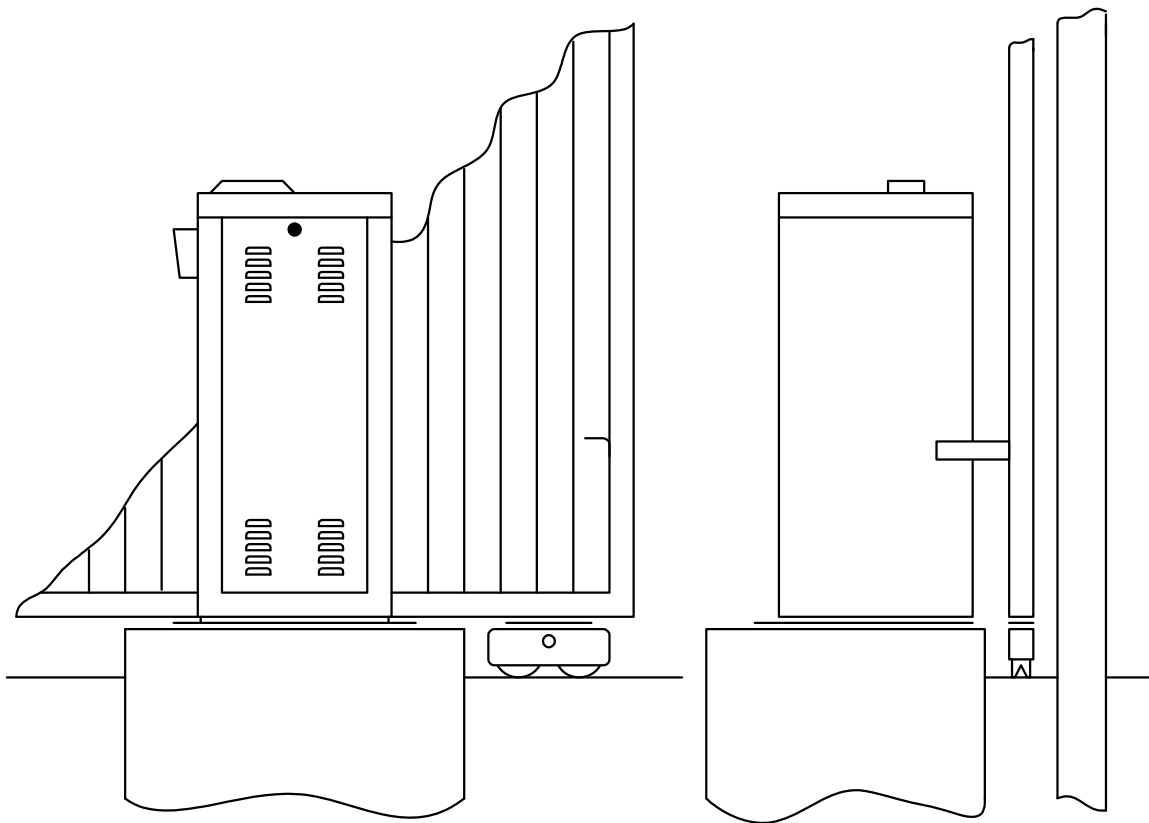

1.5 MOUNTING STAND INSTALLATION

1. Construct a form for the mounting pad according to the specifications shown below. Be sure to level the top edge of the form and that the top of the form is a minimum of four (4) inches above ground level. We suggest that you contact the local building department to determine the required depth of the pad since soil conditions and code requirements vary from city to city.
2. Set conduits, reinforcing bars and/or wire mesh if required. The number of conduits is determined by the application requirements. We suggest using a minimum of four (4) conduits. 1-High voltage power lines; 2-Low voltage control lines; 3-Loop lead-in wires (open loop); 4-Loop lead-in wires (reverse loops). Conduits can be set in the areas indicated in the illustration. **See SECTION 2.** Set additional conduits as required for your application. **NOTE:** If conduits are not set in the pad, they can be routed to a J box where connections to the operator can be made after it is installed. There are four (4) ½-inch knockouts in the operator for this purpose.

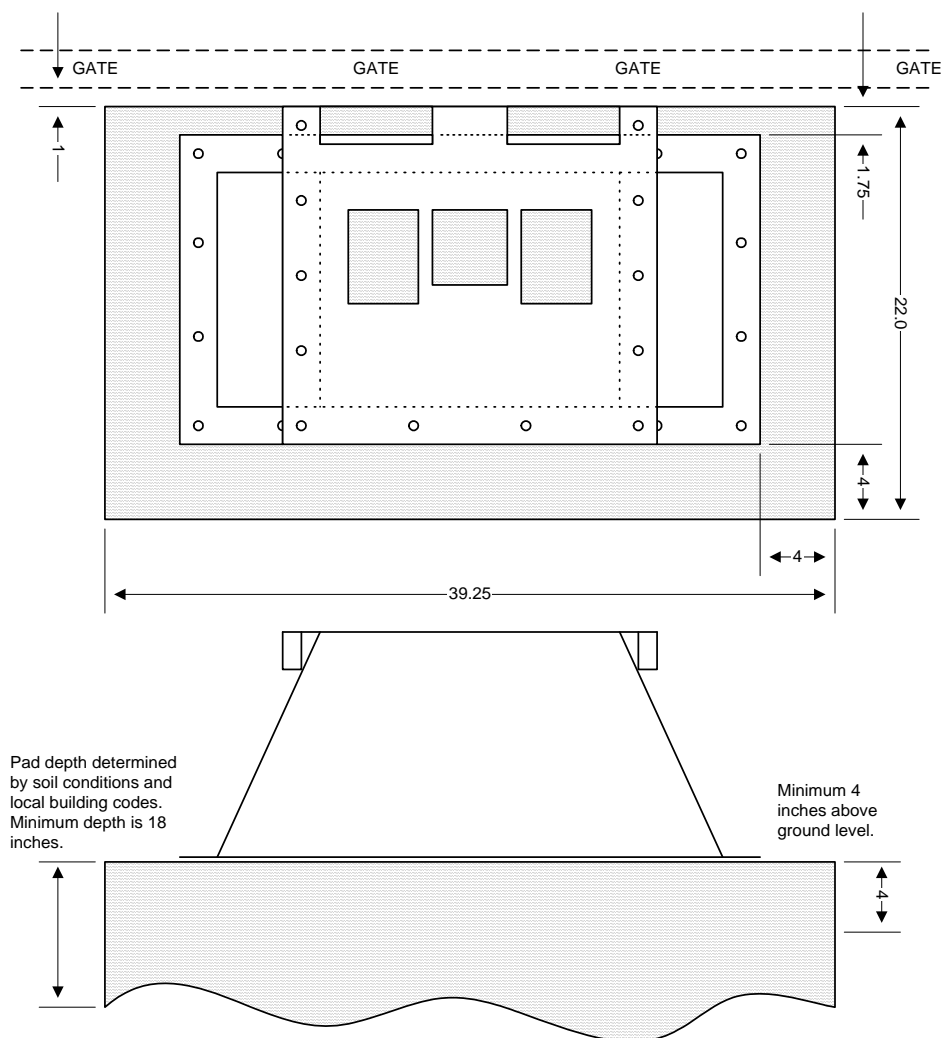

3. Mix the concrete according to the manufacturers instructions. Pour the mixture into the form and tamp. Level and finish the surface after pouring is complete. **Do not set anchor bolts in the concrete.** Sleeve anchors should be used to secure the operator to the pad. This allows greater flexibility in positioning the operator on the pad.
4. Allow the pad to cure for 48 hours before removing the forms or mounting the operator.
5. Once the pad has cured, place the operator-mounting stand on the pad in the proper position; 4-inches from the front and sides of the pad and 1-inch from the rear of the pad. **The operator-mounting stand must be parallel to the gate.**
6. Once the stand is in the proper position on the pad, secure the operator-mounting stand directly to the pad using 3/8 or 1/2 x 3 sleeve anchors. **Be sure that the operator-mounting stand is parallel to the gate.**
7. After securing the mounting stands to the pad, place the operator onto the mounting stand and secure it with the hardware provided. **CAUTION: the operator is heavy. Two persons are required to lift the operator onto the mounting plate.**

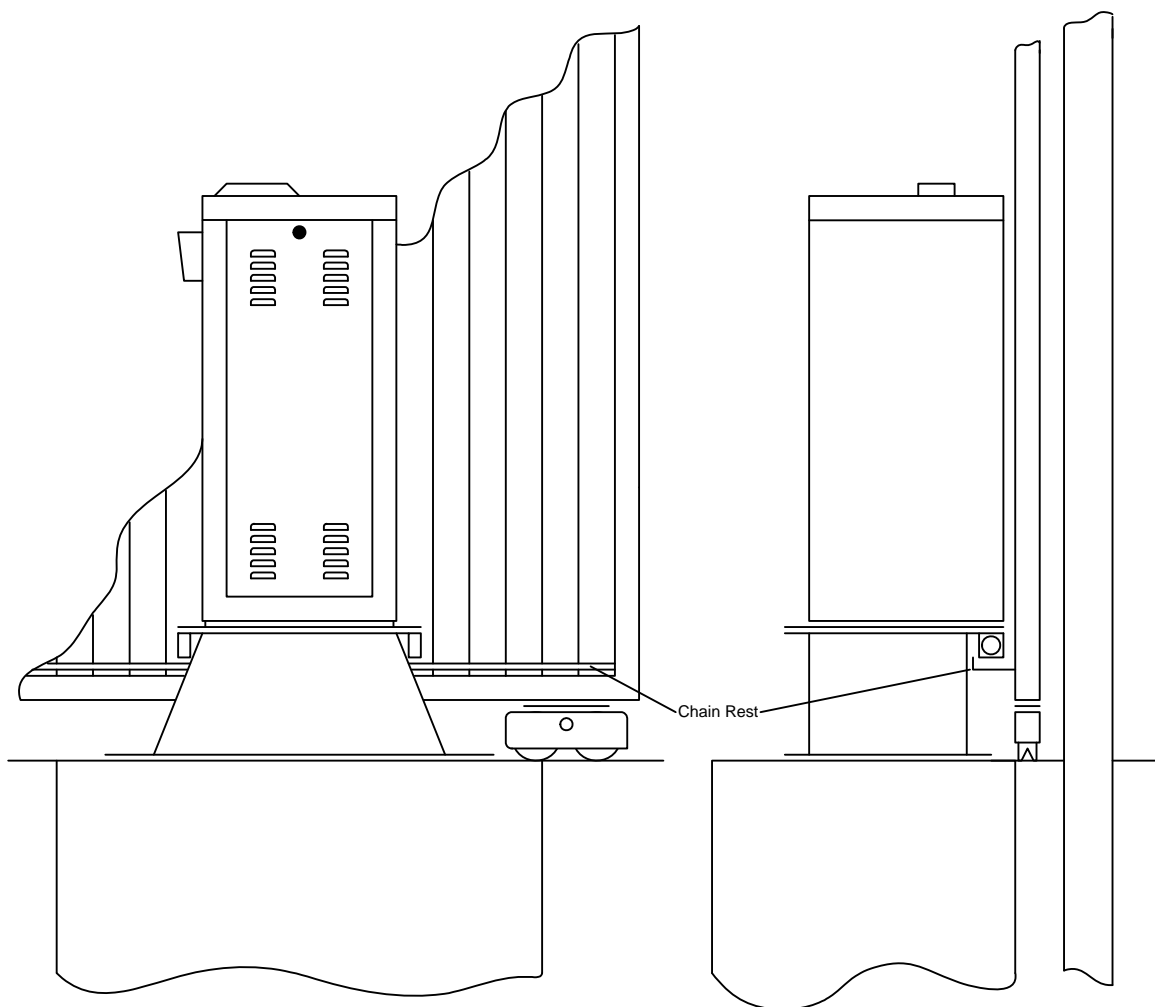

1.6 CHAIN INSTALLATION

1. Secure the chain brackets to each end of the gate so that the brackets will be level with the chain where it exits the operator. Brackets should be attached to the inside of the frame so that the chain bolts, when attached, do not protrude beyond the frame of the gate.
2. Route the chain through the gate operator.
3. Attach the chain to the chain bolts using the master links supplied, and then attach the chain bolts to the chain brackets using the hardware supplied. Make any adjustments to the chain length at this time.
4. Adjust the chain bolts to tighten the chain. The chain should sag no more than one (1) inch per 10 feet of travel. Do not over tighten the chain. **IMPORTANT!! Be sure that the chain is parallel to the gate. Installing the chain in any other manner will cause excessive noise, chain idler wear and chain stretching.**

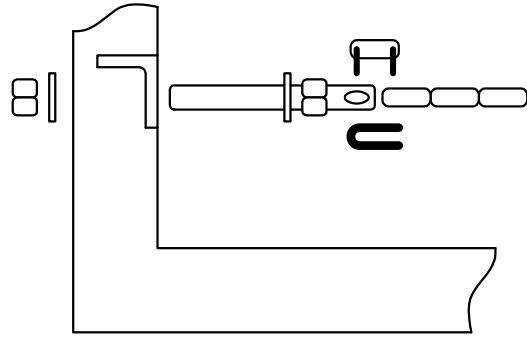

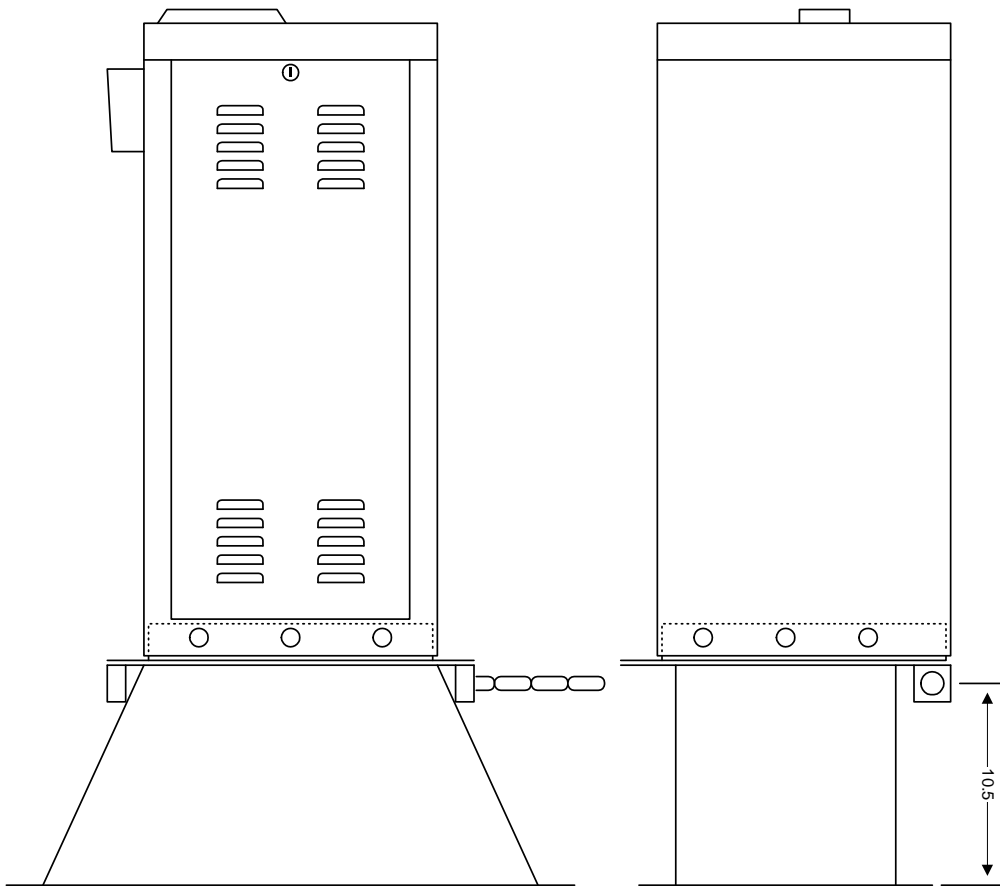
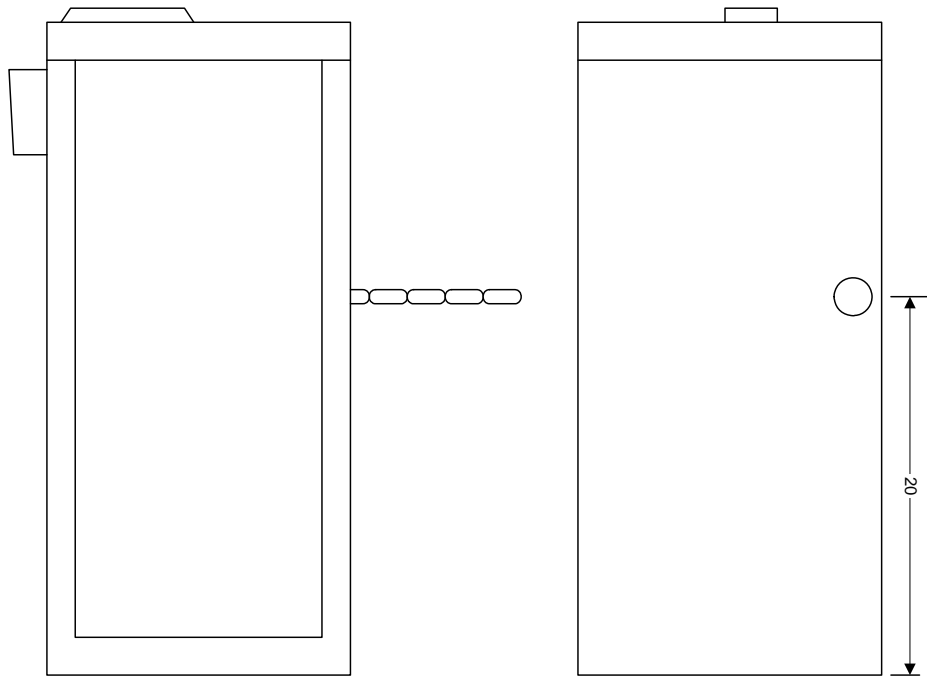

1.7 WARNING SIGN INSTALLATION

This DoorKing slide gate operator is shipped with two warning signs. The purpose of the warning signs is to alert uniformed persons, and to remind persons familiar with the system, that a potential hazard may exist so that appropriate action can be taken to avoid the hazard or to reduce exposure to the hazard.

1. Permanently install the supplied warning signs in locations so that the signs are visible by persons on both sides of the gate.
2. Use appropriate hardware such as wood or metal screws (not supplied) to install the warnings.



SECTION 2 – WIRING

Before attempting to connect any wiring to the operator, be sure that the circuit breaker in the electrical panel is in the OFF position. Permanent wiring must be installed to the operator as required by local electrical codes. It is recommended that such work be performed by a licensed electrical contractor.

Since building codes vary from city to city, we highly recommend that you check with your local building department prior to installing any permanent wiring to be sure that all wiring to the operator (both high and low voltage) complies with local code requirements.

THIS GATE OPERATOR MUST BE PROPERLY GROUNDED!!

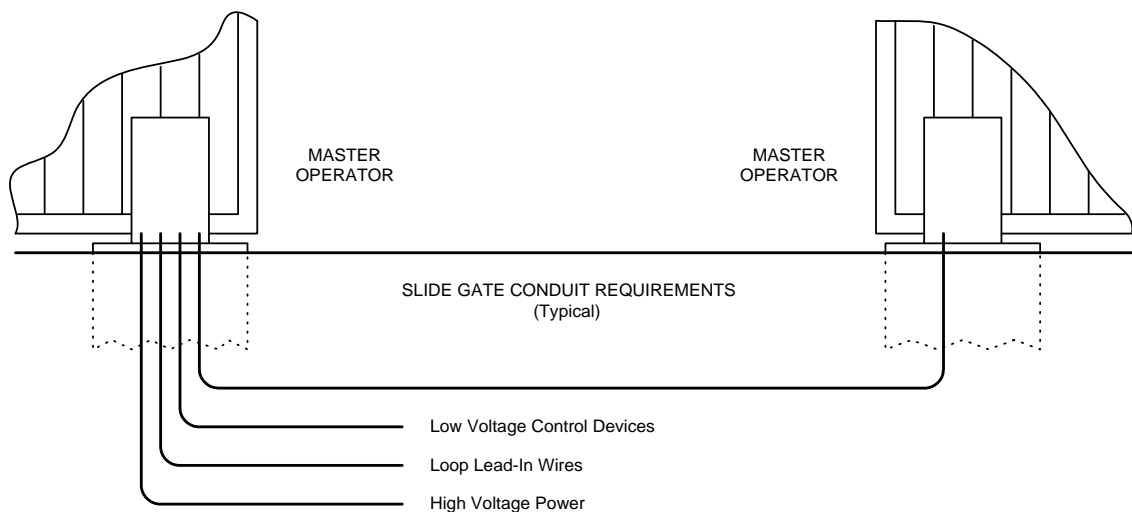

- The conduit requirements shown are for a typical slide gate operator installation (the slave operator is shown for those applications where a slave operator may be used). The conduit requirements for your application may vary from this depending on your specific needs.
- Use only sweeps for conduit bends. Do not use 90° connectors as this will make wire pulls very difficult and can cause damage to wire insulation.
- We suggest that minimum ¾-inch conduit be used.
- Be sure that all conduits are installed in accordance with local codes.

2.1 HIGH VOLTAGE CONNECTIONS

Use the table below to determine high voltage wire size requirements. The distance shown in the chart is measured in feet from the operator to the power source. If power wiring is greater than the maximum distance shown, it is recommended that a service feeder be installed. When large gauge wire is used, a separate junction box must be installed for the operator connection. The wire table is based on stranded copper wire. Wire run calculations are based on a maximum 3% voltage drop on the power line, plus an additional 10% reduction in distance to allow for other losses in the system.

INPUT POWER	AMPS	WIRE SIZE / DISTANCE IN FEET			
		12 AWG	10 AWG	8 AWG	6 AWG
3 HP: 208/230 VAC 3 ϕ	12.4	190	310	490	790

- Route incoming high voltage power through conduit and into the operator up the right side of the control box.
- Be sure wiring is installed in accordance with local codes. Be sure to color code all wiring.
- It is recommended that a surge suppresser be installed on the high voltage power lines to help protect the operator and circuit board from surges and power fluctuations.

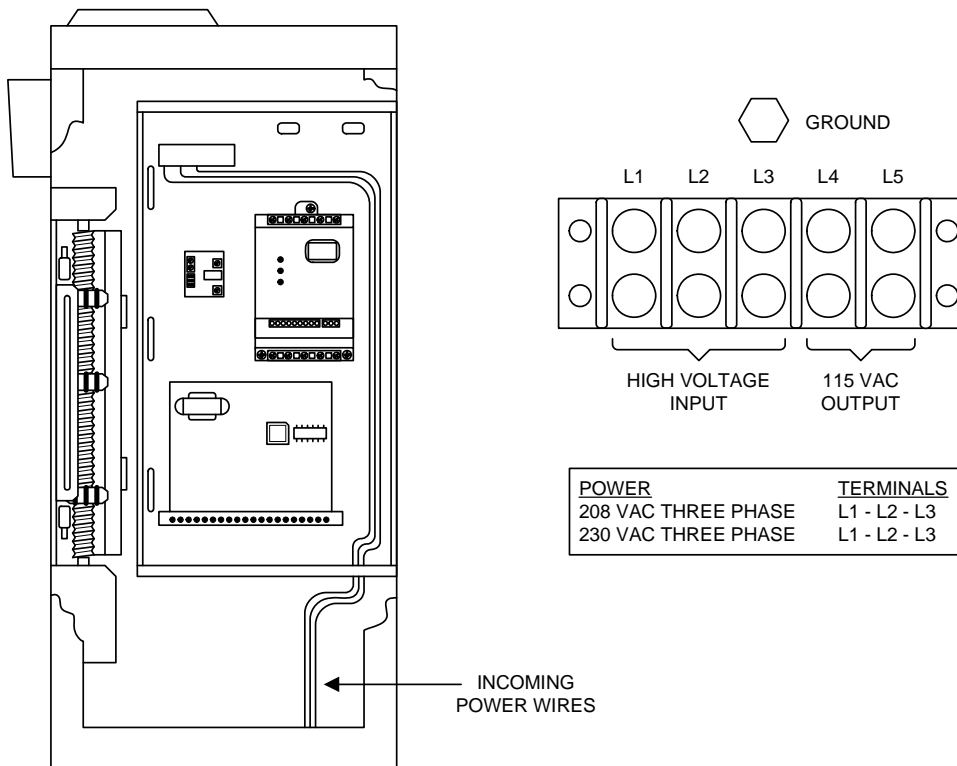

2.2 CONTROL WIRING

Controls must be far enough from the gate so that the user is prevented from coming in contact with the gate while operating the controls. Outdoor or easily accessible controls should have a security feature to prevent unauthorized use.

- Connect optional control devices to the operator terminal strip as shown below. Be sure that all electrical connections are made in accordance with local electrical codes. Use 18 AWG wire for all low voltage wiring, maximum distance 3000 feet. Use a low voltage surge suppresser, DoorKing P/N 1878-010 if low voltage wire runs exceed 1000 feet. All inputs to the terminal strip must be NORMALLY OPEN.
- **Reverse / Stop input (term 6) only functions while the gate is in the closing cycle and should not be used as an input for a secondary entrapment prevention device. See Section 2.3 for secondary entrapment prevention device wiring.**
- Do not power any devices from the circuit board other than a low voltage radio receiver as shown. Power available at terminal 3 is limited to 250 ma at 24 VAC. **Three-button control station must be DoorKing P/N 1200-006 or 1200-007 only.** Others will not work.

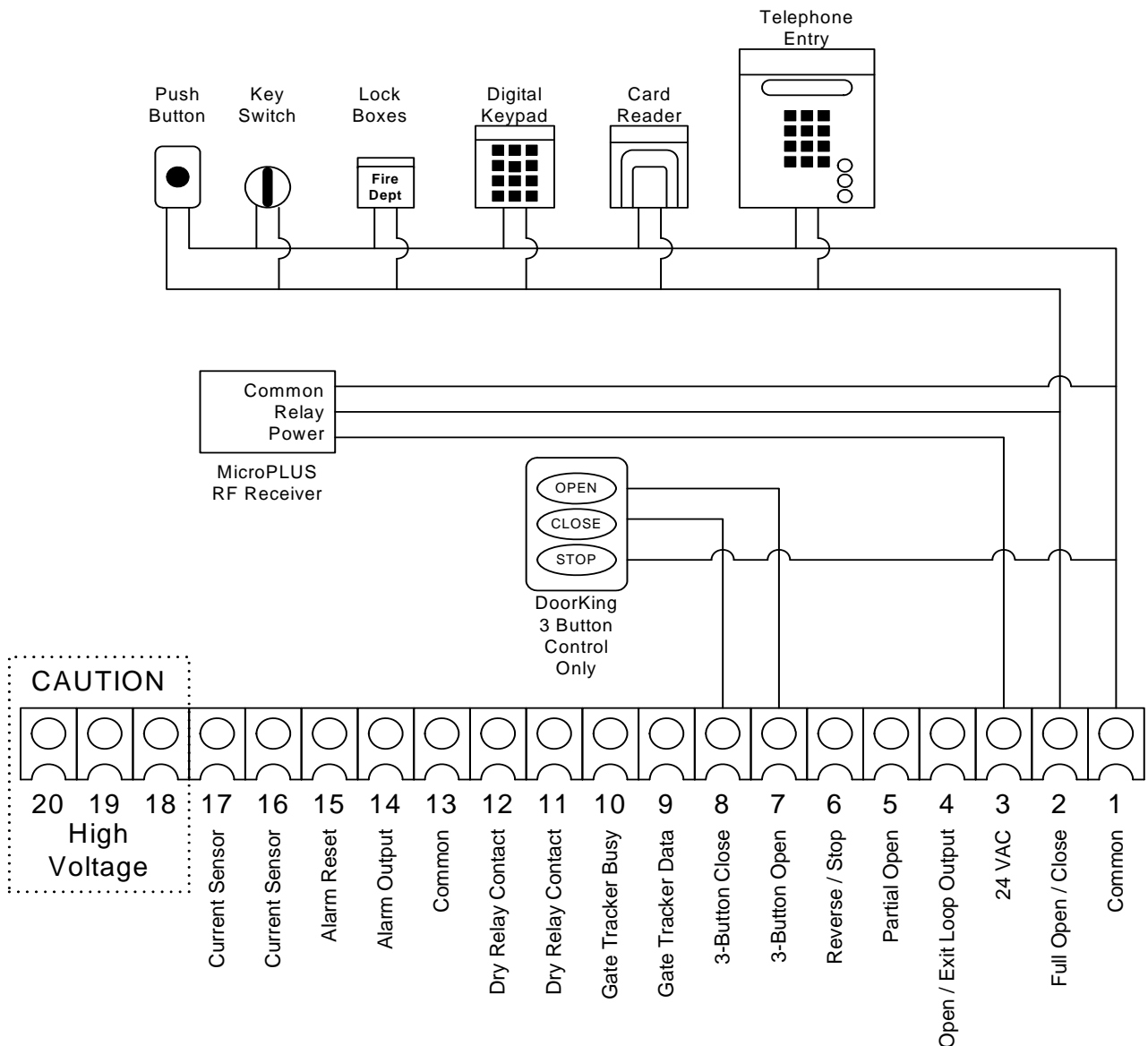

2.2.1 HIGH SPEED EMERGENCY CLOSE

The 9530 has a special High Speed Emergency Close input. When this input is activated, the operator will close the gate at the rate set with the high speed adjustment – up to 6-ft/sec.

WARNING! The Emergency Close activating device must have a security feature so that accidental activation of this input is not possible. Once the Emergency Close feature is activated, the gate cannot be stopped. The gate will run to the full closed position and all inputs will be deactivated until the operator is reset (power is removed and then restored).

The emergency close feature is intended to be used only when a perimeter security breach is imminent, for example; an unidentified vehicle is traveling at a high rate of speed towards the perimeter gate. By activating the emergency close feature, the access gate can be closed and secured in a manner of seconds.

- Connect the Emergency Close activating device to the input terminals on the small speed control circuit board. Be sure that all electrical connections are made in accordance with local electrical codes. Use 18 AWG wire for all low voltage wiring, maximum distance 3000 feet. Use a low voltage surge suppresser, DoorKing P/N 1878-010 if low voltage wire runs exceed 1000 feet. The Emergency Close input is NORMALLY OPEN.

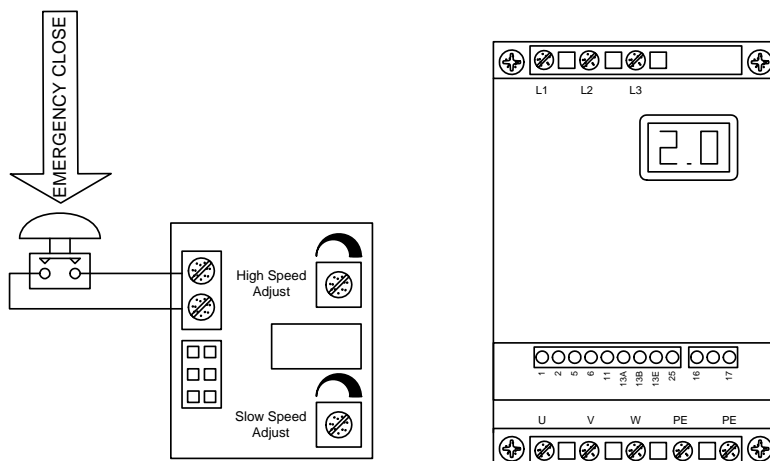

2.3 ENTRAPMENT PREVENTION DEVICE WIRING

Entrapment prevention devices must be installed to insure a safe operating environment and to reduce the risk of personnel entrapment. This operator has inputs for non-contact sensors and contact sensors for both opening and closing gate cycles. Entrapment prevention may be provided by a combination of both type sensors. See Section 5.4 for a list of acceptable secondary entrapment prevention devices.

2.3.1 NON-CONTACT SENSORS

- Disconnect power to the gate operator before installing the non-contact sensors.
- See diagram below for suggested placement of sensors. (Diagram is for illustration purposes only. Actual placement of the sensors is dependent on the installation requirements). One or more non-contact sensors shall be located where the risk of entrapment or obstruction exists, such as the perimeter reachable by a moving gate or barrier.
- Use only UL listed (or equivalent) non-contact sensors.
- Connect the non-contact sensors as shown below to the auxiliary terminal strip located on the 4404 control board. Inputs from photo-beam to circuit board are NORMALLY OPEN.
- Diagram does not show power wiring to photo-beams.
- Open photo-beam must be placed so that it covers that portion of the fence that the gate covers when it is fully open.

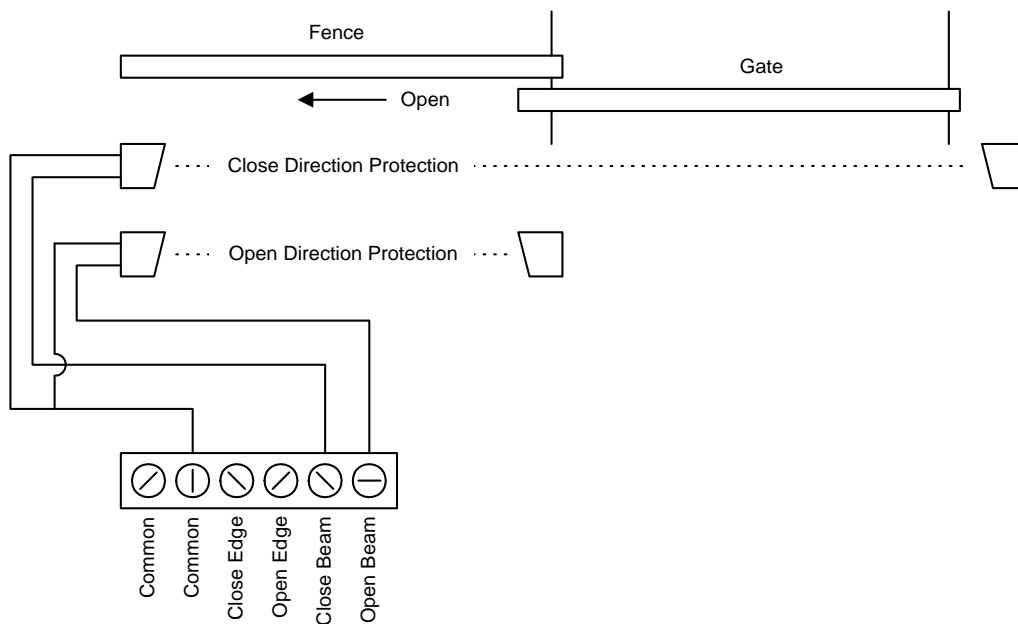

2.3.2 CONTACT SENSORS

- Disconnect power to the gate operator before installing the contact sensors.
- Connect the contact sensors as shown below to the auxiliary terminal strip located on the 4404 control board.
- Contact sensors may be located at the leading edge, trailing edge, and post mounted both inside and outside of the vehicular sliding gate. Additional contact sensors may be added for additional protection where an entrapment zone may exist.
- Hardwired contact sensors must be located and wiring arranged so that the communication between the sensor and the gate operator is not subjected to mechanical damage.
- Inputs from sensing edges/receiver to circuit board are NORMALLY OPEN.
- Diagram does not show power wiring to RF receiver.

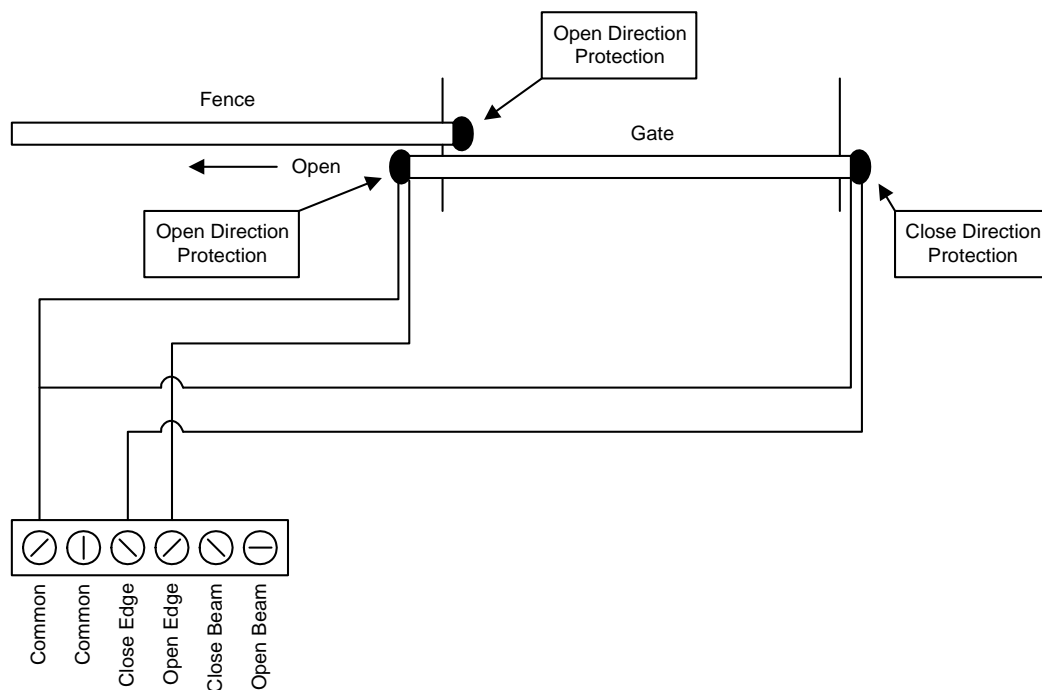

2.4 LOOP DETECTOR WIRING

If non-contact sensors are not utilized and installed as described in section 2.3.1, then loops and loop detectors must be installed with this gate operator to prevent the gate from accidentally closing on vehicles that may be in the path of the gate.

- Loop detector wiring is shown for DoorKing Plug-In loop detectors only. If other loop detectors are used, refer to the installation instructions supplied with those detectors for wiring requirements.
- If other loop detectors are used, all inputs to the terminal strip are NORMALLY OPEN. Use a separate power supply to power external detectors. Be sure that power is turned off prior to making any connections to the terminal strip.
- Loop layout shown is for a typical slide gate application with two-way traffic or one-way exit only traffic. For one-way entry only traffic, the open loop and loop detector are not needed.
- Refer to the separate Loop Information Manual (available from DoorKing) for instructions on installing loops or preformed loops.
- Reverse loops are wired in series (detail A)!

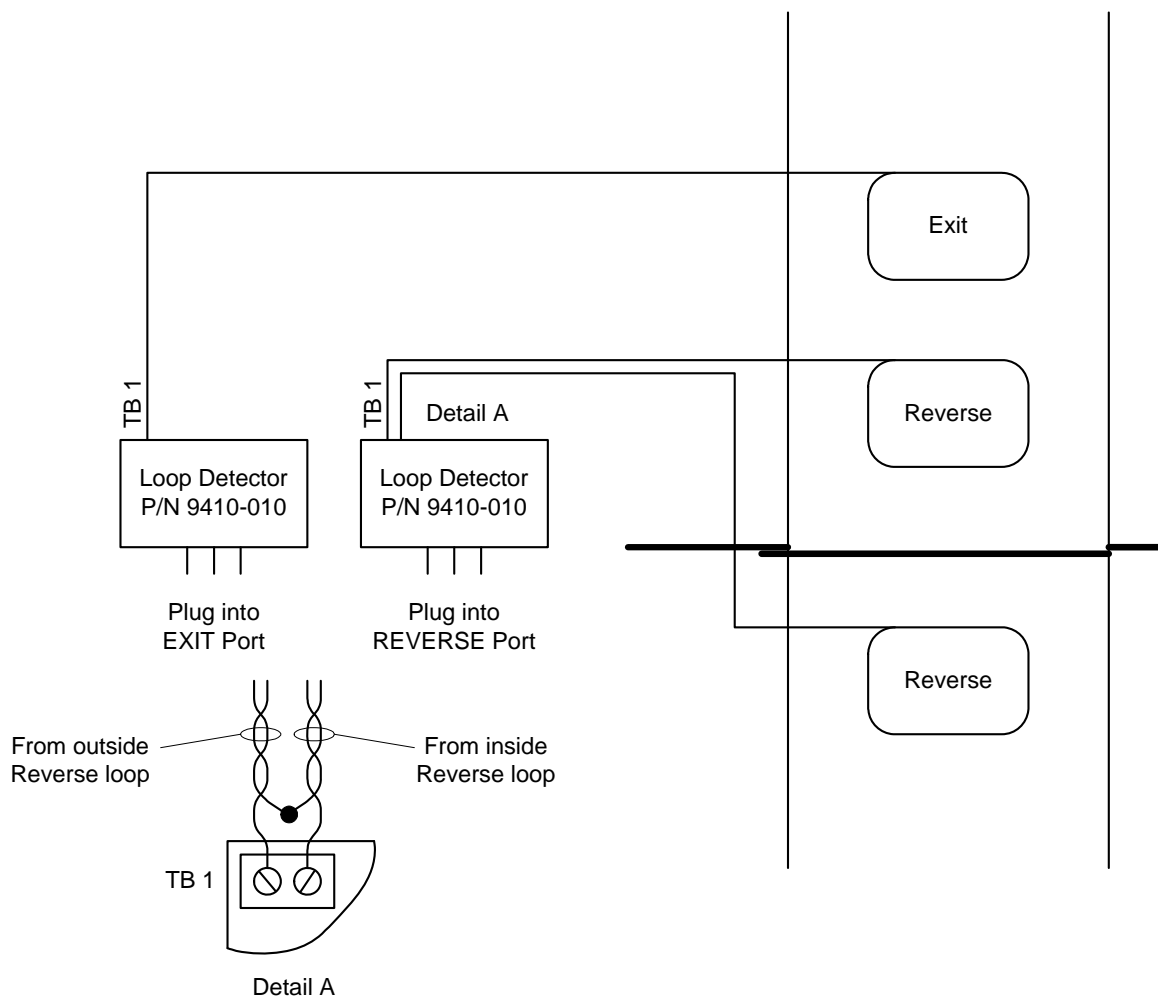

2.5 GATE TRACKER™ CONNECTIONS

This gate operator is equipped with outputs from the circuit board that will report operator status to a companion DoorKing Access Control System (Model 1833, 1835, 1837 or 1838) when equipped with an optional Tracker expansion board. This report includes items such as gate operator cycle count, any shorted inputs, loop detector problems, any attempts to force the gate open, if the gate has struck anything during the open or close cycle, power interruptions, etc.

Gate Tracker™ connections are made at terminals 1, 2, 3, 9 and 10 on the main terminal strip. For more detailed information on Gate Tracker™ and wiring to the Tracker expansion boards, refer to the Tracker Installation and Wiring Manual, DoorKing P/N 2351-010.

Maximum wire run for gate operator data to the tracker board is 500 feet using Belden #9931 shielded cable or Consolidated #5324-CL shielded cable. **Float the shield at the tracker board. Do not connect the shield to the tracker board common.**

Wire connection from the tracker board terminal P1-2 to the 4404 main terminal 2 is optional **if the gate operator is not to be activated by the tracker output relay.**

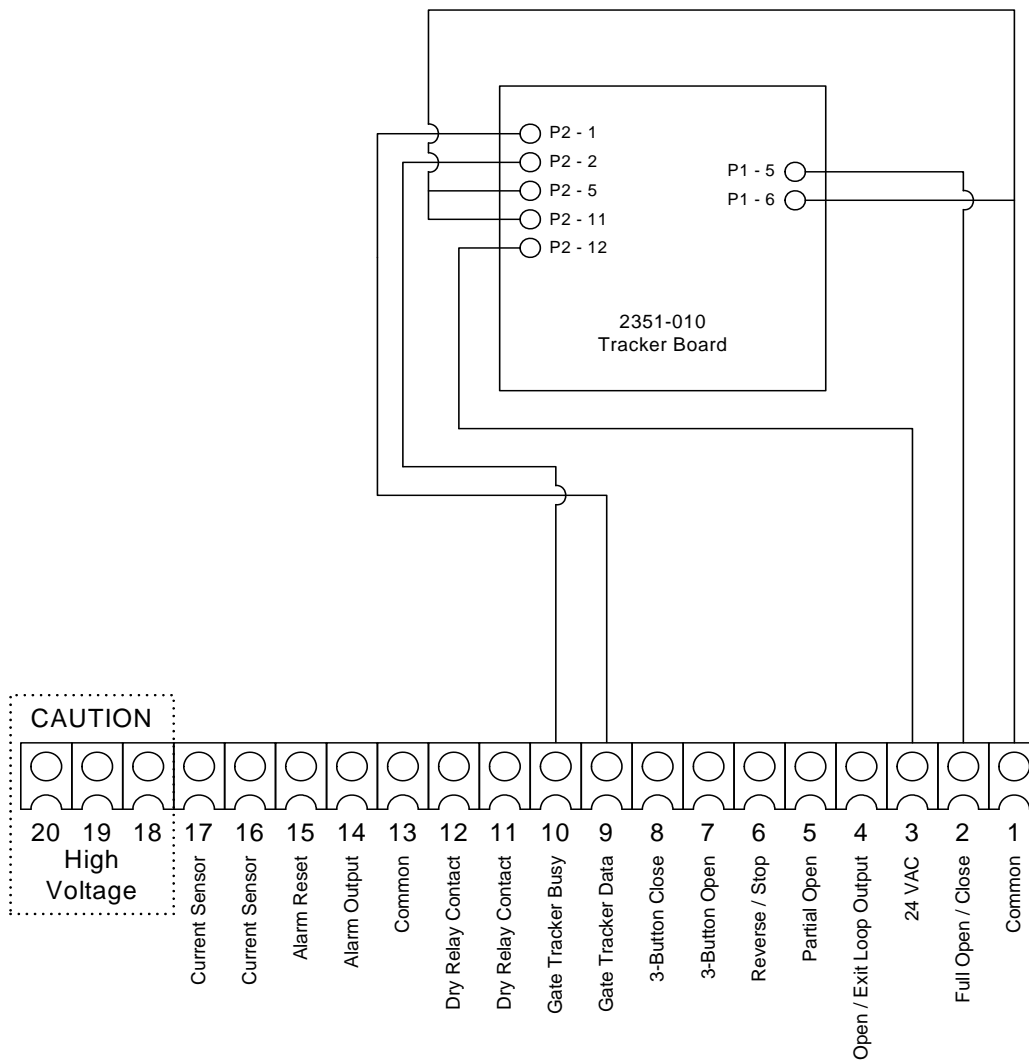

2.6 AUXILIARY DEVICES

2.6.1 ALARM RESET SWITCH

The gate operator is equipped with a reset switch that will silence the entrapment alarm and return the operator to normal operation after a hard shutdown occurs. An external alarm / reset button (P/N 1404-080) may be added provided that the following condition is met.

- The alarm-reset button must be located in the line of sight of the gate.
- Connect the normally open alarm-reset switch to auxiliary terminals 13 and 15.

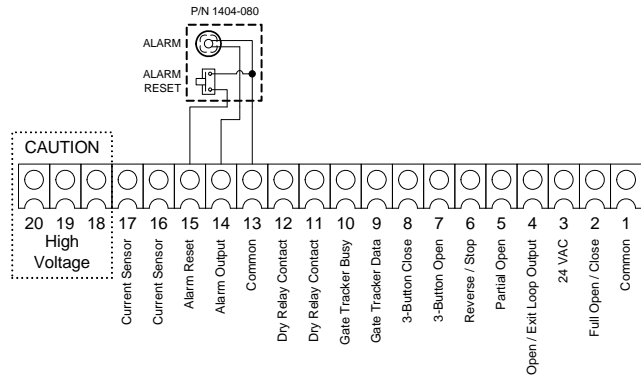

2.6.2 AUXILIARY STOP SWITCH

This circuit creates an auxiliary stop input that will stop a moving gate when activated, or will prevent the gate operator from starting if the switch is activated.

Note that this stop input is normally open and that a switch closure will activate the stop function. Because this is a normally open circuit, the stop switch is not intended and should not be used as a safety interlock device.

- This circuit cannot be used if a DoorKing 3 button control station is connected to the operator.
- Place a jumper wire from terminal 7 to terminal 8.
- Connect the stop switch to terminals 1 and 8. A magnetic switch is used in the diagram at the right for illustration purposes.

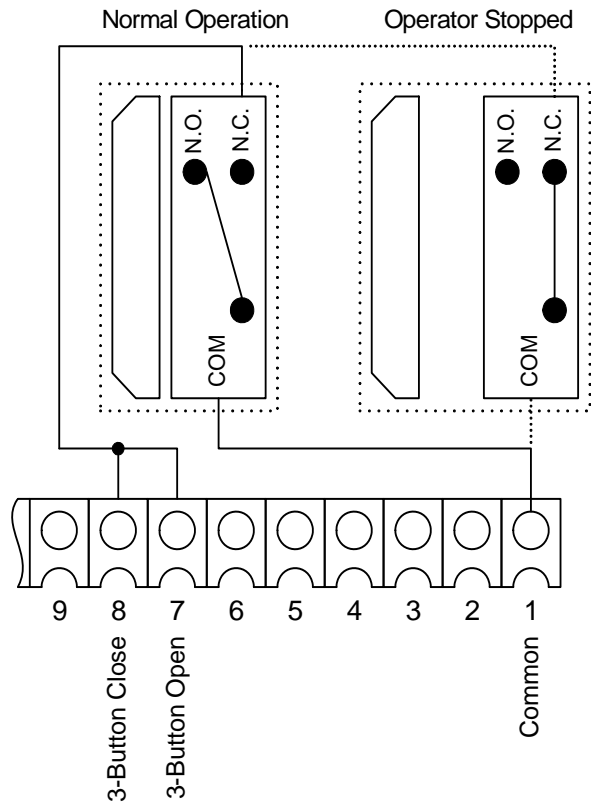

2.7 PRIMARY / SECONDARY WIRING

2.7.1 OPERATOR INTERFACE

The interface wiring between the two operators requires four (4) 18 AWG wires for control. Each operator must be connected to its own power source as described in section 2.2. The loop functions are controlled by a two-channel loop detector (P/N 9409-010) plugged into the OPEN port on the operator that is designated as the master unit. Color code shown assumes use of DoorKing interface cable, part number 2600-755 (30 ft.), 2600-756 (40 ft.), 2600-757 (50 ft.).

1. Connect the primary / secondary wiring main terminals 1, 2, 6 and external sensor terminal 2 as shown below. Be sure that power to both operators is OFF.
2. Set SW 1, switch 3 to the OFF position in the primary operator. Place a jumper from terminal 2 to terminal 4.
3. Plug the 9409 loop detector into the OPEN loop port. Connect the leads from the OPEN loop to TB 1. Connect the leads from the REVERSE loop(s) to TB 2. Connect TB 3 Normally Open (N.O.) to terminal 6. Connect TB 3 Common (C) to terminal 1.
4. Connect any other OPEN devices to terminals 1 and 2. Connect standard external REVERSING devices to terminals 1 and 6. See section 2.7.2 for entrapment prevention device wiring for primary / secondary operators.

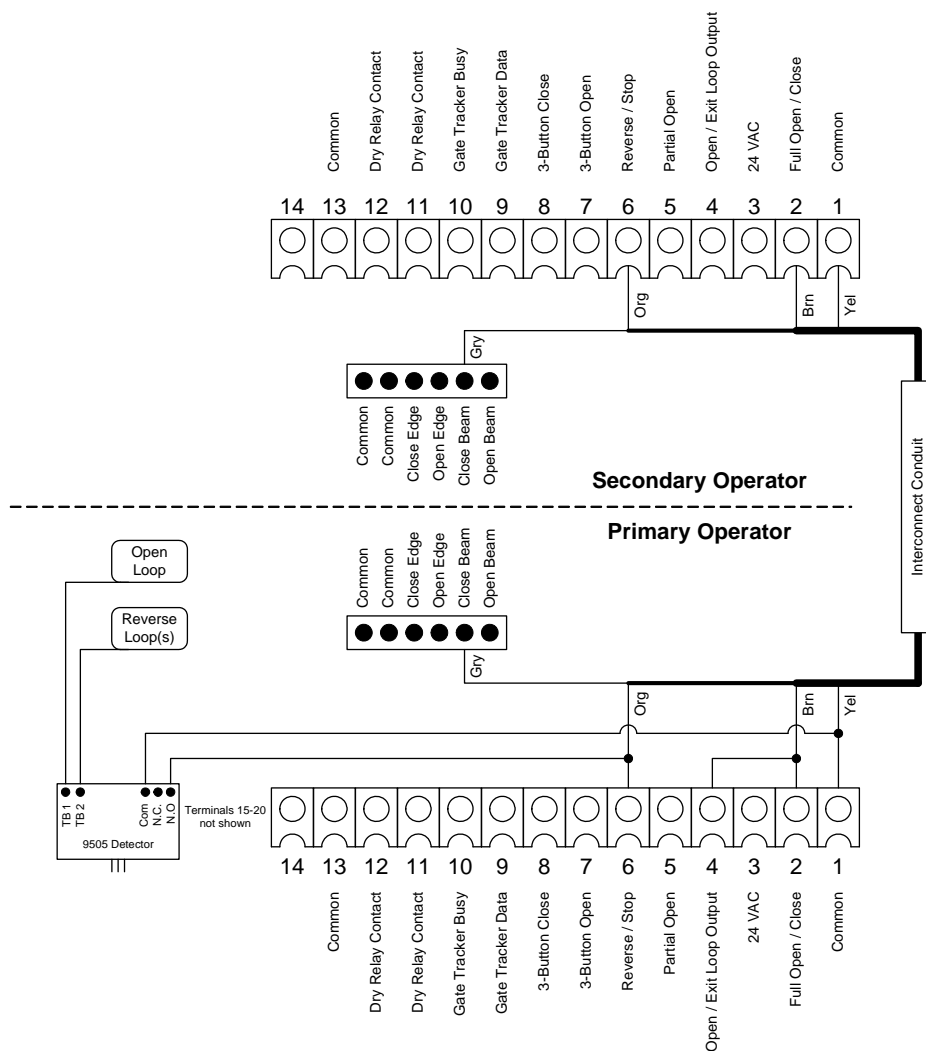

2.7.2 ENTRAPMENT PROTECTION DEVICE WIRING

Entrapment protection for slide gate operators connected in a primary / secondary configuration will require three sets of photo-beams to insure protection.

- One photo-beam is directed across the roadway and connected to the CLOSE photo-beam input on the auxiliary terminal strip of both the master and slave operator. This photo-beam is active in the close direction only and will not affect the movement of the gates while the gates are opening.
- Two photo-beams are required to protect the open direction of the gates - one for the master operator and one for the slave operator. These photo-beams are connected to the OPEN photo-beam input on the auxiliary terminal strip in their respective operator. These photo-beams are active in the open direction only. If a beam is interrupted while the gate(s) are in the open cycle, only the gate that is controlled by the interrupted beam will stop, the other gate will continue in the open direction.

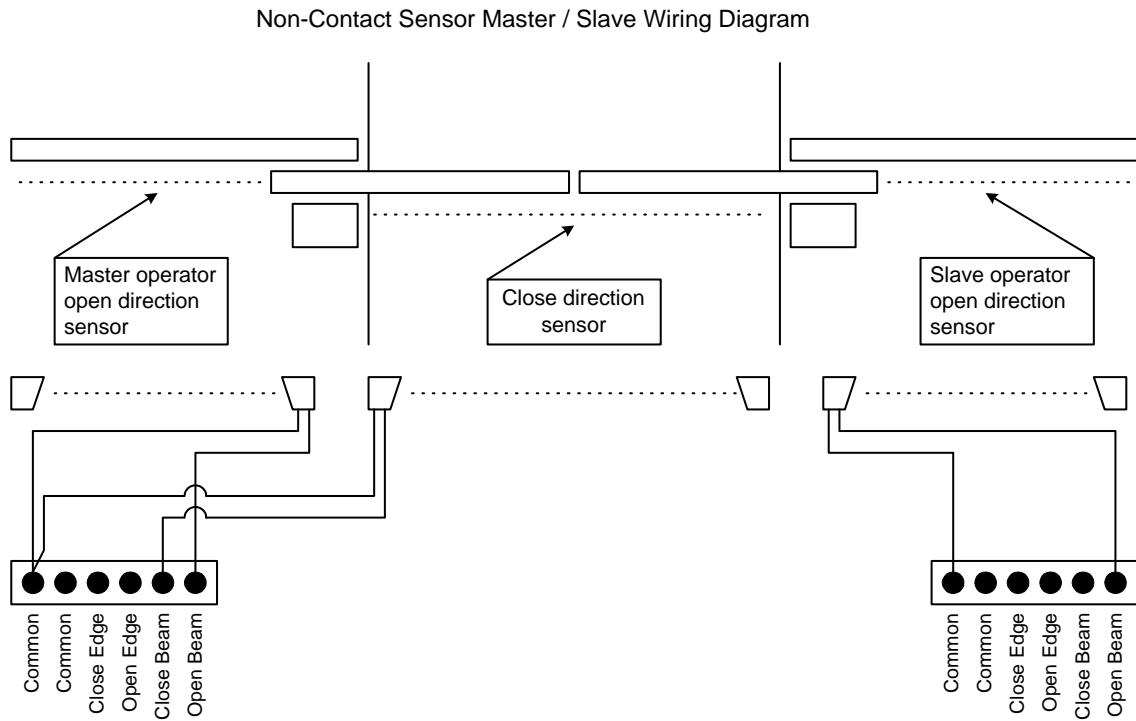

2.8 TERMINAL IDENTIFICATION AND DESCRIPTION

2.8.1 MAIN TERMINAL (P1)

1. LOW VOLTAGE COMMON
2. OPEN / CLOSE INPUT
When gate is closed, input will open gate to full position.
When gate is open and auto close timer is turned on, input will re-set and hold timer.
When gate is open and auto close timer is turned off, input will close gate.
When gate is closing, input will reverse gate.
3. 24 VAC RADIO RECEIVER POWER, 250 MA MAXIMUM
4. FULL OPEN – CLOSE / EXIT LOOP LOGIC OUTPUT
If SW 1, switch 3 is OFF, this terminal becomes the logic output of the loop detector plugged into the EXIT loop port (DoorKing loop detectors only).
If SW 1, switch 3 is ON, this terminal is identical to terminal 2.
5. PARTIAL OPEN INPUT
This input will open the gate to the mid-limit switch setting.
6. REVERSE / STOP INPUT
When gate is fully closed or in the opening cycle, this input has no affect on the gate operator.
When gate is open and auto close timer is turned ON, input will re-set and hold timer.
When gate is open and auto close timer is turned OFF, input will prevent gate from closing.
When gate is closing, input will REVERSE gate if SW 1, switch 7 is OFF.
When gate is closing, input will STOP gate if SW 1, switch 7 is ON.
7. 3-BUTTON OPEN INPUT - Use with DoorKing 3 button control stations only (P/N 1200-006 and 1200-007).
8. 3-BUTTON CLOSE INPUT - Use with DoorKing 3 button control stations only (P/N 1200-006 and 1200-007).
9. GATE TRACKER - DATA
10. GATE TRACKER - BUSY
11. DRY RELAY CONTACT
Operation of relay is dependent on setting of SW 1, switches 4 and 5. Relay contacts can be set for Normally Open (NO) or Normally Closed (NC) operation. Contact rating is 1 amp maximum at 24 Volts.
12. DRY RELAY CONTACT
13. LOW VOLTAGE COMMON
14. ALARM OUTPUT – Can also be connected to external alarm reset (P/N 1404-080)
15. ALARM RESET – Can also be connected to external alarm reset (P/N 1404-080)
16. CURRENT SENSOR
17. CURRENT SENSOR
18. 120 VAC HOT INPUT TO CIRCUIT BOARD
19. 120 VAC NEUTRAL INPUT TO CIRCUIT BOARD
20. EARTH GROUND / CHASSIS

2.8.2 LIMIT SWITCH CONNECTOR (P2)

The limit switch connector is located at the upper left-hand corner of the 4404 circuit board and provides input to the circuit board from the limit switches.

1. FULL LIMIT
2. SLOW DOWN
3. PARTIAL LIMIT
4. SLOW DOWN
5. FULL LIMIT
6. LIMIT ENABLE
7. LIMIT COMMON
8. LIMIT COMMON

2.8.3 REVERSING DEVICE CONNECTOR (P5)

Entrapment prevention devices are connected here.

1. OPEN PHOTO-BEAM
This input is only active when the gate is in the opening cycle. An open photo-beam input during the opening cycle will cause the gate to stop. The gate will remain stopped until the photo-beam input is cleared, at which time the gate will resume the open cycle.
2. CLOSE PHOTO-BEAM
This input is only active when the gate is in the closing cycle. A close photo-beam input during the closing cycle will cause the gate to stop. The gate will remain stopped until the photo-beam input is cleared, at which time the gate will resume the close cycle.
3. OPEN EDGE
This input is only active when the gate is in the opening cycle. An open edge input during the opening cycle will cause the gate to stop and then reverse.

If the gate reaches the full closed position, the gate will remain closed, ignore any maintained inputs and enter a soft shutdown condition. NOTE: If the gate was initially activated by a time clock with a contact closure across the gate operator open input, this input will be ignored until another input (open loop, reverse loop. etc.) is received by the gate operator.

If a close edge sensor is activated prior to the gate reaching the full closed position, the gate will stop and enter a soft shutdown condition.

4. CLOSE EDGE
This input is only active when the gate is in the closing cycle. A close edge input during the closing cycle will cause the gate to stop and then reverse.

If the gate reaches the full open position, the timer will automatically close the gate (if it is turned on). Once the gate starts to close again, if the close edge input is activated a second time prior to the gate reaching the full closed position, the operator will stop and reverse and will enter a soft shutdown condition.

If an open edge sensor is activated prior to the gate reaching the full open position, the gate will stop and enter a soft shutdown condition.

5. COMMON
Common terminal for the secondary entrapment protection device inputs.
6. COMMON

SECTION 3 - ADJUSTMENTS

The switch settings and adjustments in this chapter should be made after your installation and wiring to the operator(s) is complete. Whenever any of the programming switches on the circuit board are changed, power must be shut-off, and then turned back on for the new setting to take effect.

3.1 CIRCUIT BOARD ADJUSTMENTS

- Set the DIP-switches on the circuit board to the desired setting. See switch-setting charts in section 3.2.
- Auto close timer (when turned on) can be set from 1 second (full counter clockwise) to approximately 23 seconds (full clockwise).
- Dry contact relay (terminals 11-12) can be set for Normally Open (NO) or Normally Closed (NC) operation by placing the relay shorting bar on the NO or NC pins respectively.
- Power LED indicates that low voltage power is applied to the circuit board. Input LEDs should be OFF and will only illuminate when the input is activated. The limit LED will be ON when the respective limit switch is activated.

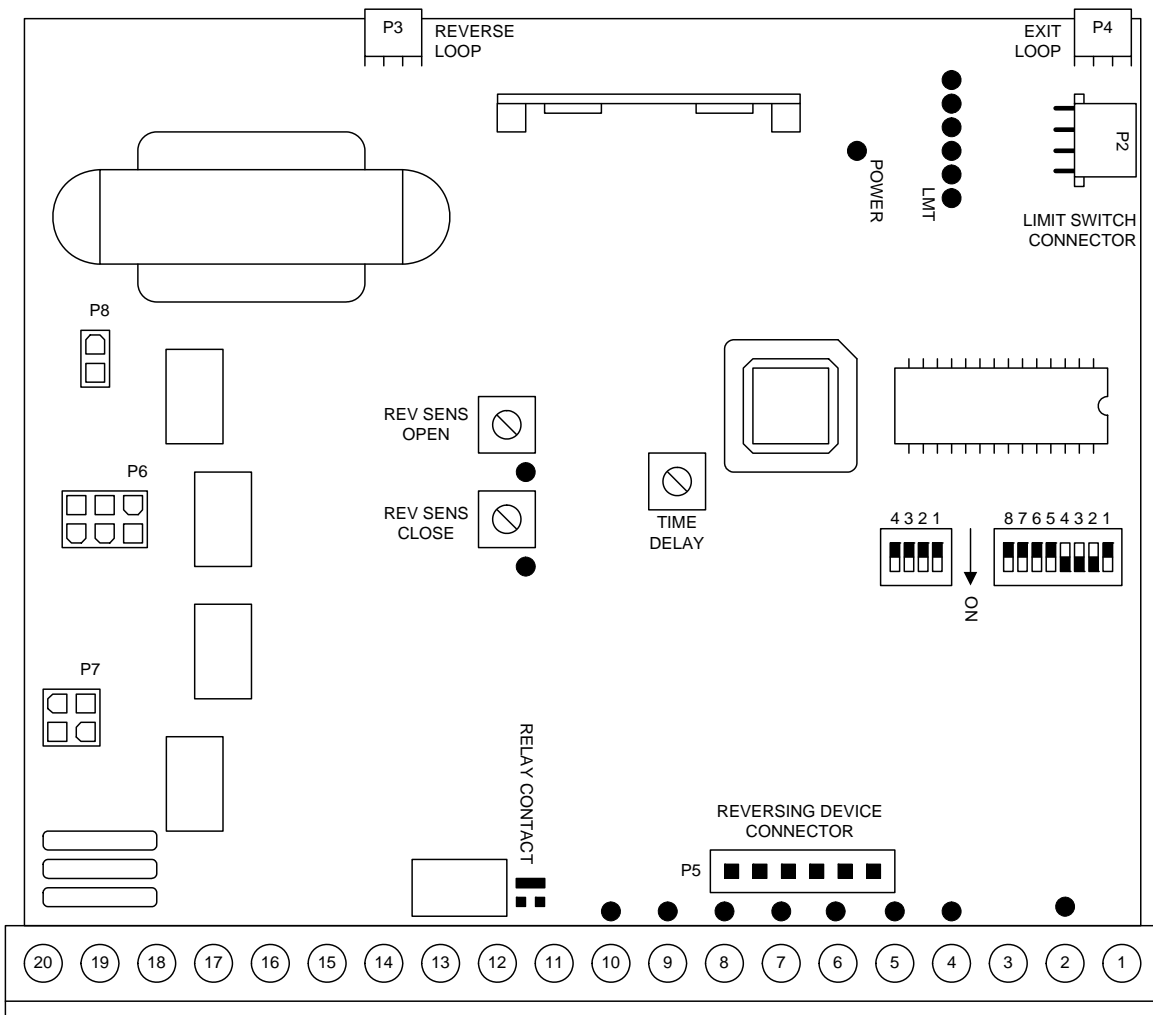

3.2 SWITCH SETTINGS

The two DIP-switches located on the circuit board are used to program the operator to operate in various modes and to turn on or off various operating features. Whenever a switch setting is changed, power to the operator must be turned OFF and then turned back on for the new setting to take affect. **Check and review ALL switch settings prior to applying power to the operator.**

CAUTION: Switches on the circuit board are numbered right to left, not left to right.

SW 1 (RIGHT SWITCH)			
SWITCH	FUNCTION	SETTING	DESCRIPTION
1	Direction	OFF ON	Changes open / close direction of operator.
2	Auto Close Timer	OFF ON	Auto-close timer is OFF. Manual input required to close gate. Auto-close timer is ON. Adjustable from 1-23 seconds.
3	Open Loop Output	OFF ON	Switches logic-level output of EXIT loop port to terminal 4. Normal Setting. Control board responds internally to loop detector plugged into exit loop port.
4 & 5	Relay & LED	4-OFF 5-OFF 4-OFF 5-ON 4-ON 5-OFF 4-ON 5-ON	Relay activated and LED on when gate is FULL OPEN. Relay activated and LED on when gate is NOT CLOSED. Relay activated and LED on when gate is OPENING and OPEN. Relay activated and LED on when gate is OPENING or CLOSING.
6	Warn Before Operate	OFF ON	Normal setting. Alarm will sound 2-3 seconds prior to the gate starting.
7	Reverse Stop	OFF ON	Normal Setting. Input to terminal 7 will REVERSE gate during close cycle. Input to terminal 7 will STOP gate during close cycle.
8	Quick Close	OFF ON	Normal gate operation. Opening gate will stop and begin to close as soon as all reversing inputs (loops, beams) are clear regardless of the open position of the gate.

SW 2 (LEFT SWITCH)			
SWITCH	FUNCTION	SETTING	DESCRIPTION
1	Self Test (see note 1)	OFF ON	Normal setting. Run self-test – bench test only.
2	Open Uphill	OFF ON	Normal setting. Turn ON if gate opens in an uphill direction.
3	Open Downhill	OFF ON	Normal setting. Turn ON if gate opens in a downhill direction.
4	Spare	OFF ON	Normal Setting.

NOTES:

1. Do not run the self-test while the gate operator is connected to the gate. This self-test feature is designed for bench-testing only.

3.2.1 SW 1 (RIGHT SWITCH) DESCRIPTION AND FUNCTION

Switch 1: Set so that the operator cycles open upon initial power up and open command. If the operator cycles close, turn power off and change the setting on this switch.

Switch 2: Turns the auto close timer on or off. Set from 1 to 23 seconds. **Loops and loop detectors, photoelectric cells, or other like devices must be installed when the auto close timer is used to prevent the gate from closing on vehicular traffic.**

Switch 3: Determines if the output of the loop detector (DoorKing loop detectors only) plugged into the EXIT port will be sent directly to the microprocessor to open the gate, or if the output is directed to terminal 4 where it can then be connected to other input terminals

Switches 4-5: These work in conjunction with each other and determine when the relay on the board will be activated. This relay can be used as a switch for various functions such as illuminating a warning light when the gate is moving, or turning on a green light when the gate is full open. If a magnetic lock is used with the gate operator, these switches must be set for magnetic lock operation which limits the relay to activate only when the gate is opening and full open.

Switch 6: Warn Before Operate, When set to the ON position, the internal alarm in the operator will sound 2-3 seconds prior to the gate starting.

Switch 7: Determines if an input to terminal 7 will reverse or stop a closing gate. If this switch is set to stop the gate (ON), once the input to terminal 7 is cleared, the gate will continue to close. This is typically used to help prevent tailgating.

Switch 8: Turning the quick-close feature on will cause the auto close timer to close the gate after 1 second, regardless of the setting of the auto close timer potentiometer. This will also cause an opening gate to stop and reverse when the reverse (loop) inputs are cleared. This feature, along with switch 7 above, is useful to prevent tailgating.

3.2.2 SW 2 (LEFT SWITCH) DESCRIPTION AND FUNCTION

Switch 1: This switch must be in the OFF position for normal operation. The self-test feature checks various functions of the operator. CAUTION - Do not run self-test with the operator connected to the gate. The drive chain must be disconnected from the operator to run the self-test.

Switch 2: Set to the OFF position for normal operation. Set to the ON position if gate OPENS in an UPHILL direction.

Switch 3: Set to the OFF position for normal operation. Set to the ON position if gate OPENS in a DOWNHILL direction.

Switch 4: Spare – leave switch in the OFF position.

3.3 LIMIT ADJUSTMENT

3.3.1 Limit Switch Adjustment

1. Turn power off.
2. Push the lock plate handle down to adjust the Open and Close limit nuts.
3. After adjusting the limit-nuts, be sure that the lock-plate is engaged in the slots on the limit-nuts to prevent them from slipping.
4. Turn power on and activate the gate operator.
5. Re-adjust the limit-nuts as necessary for full-open and full-close gate travel.
6. If using the partial open feature (input to terminal 5), adjust the middle limit nut being sure to align the magnet in the limit nut with the magnetic pick-up.

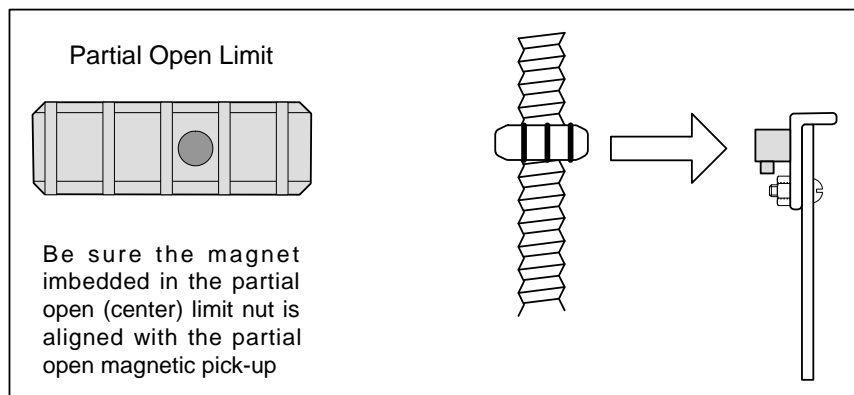
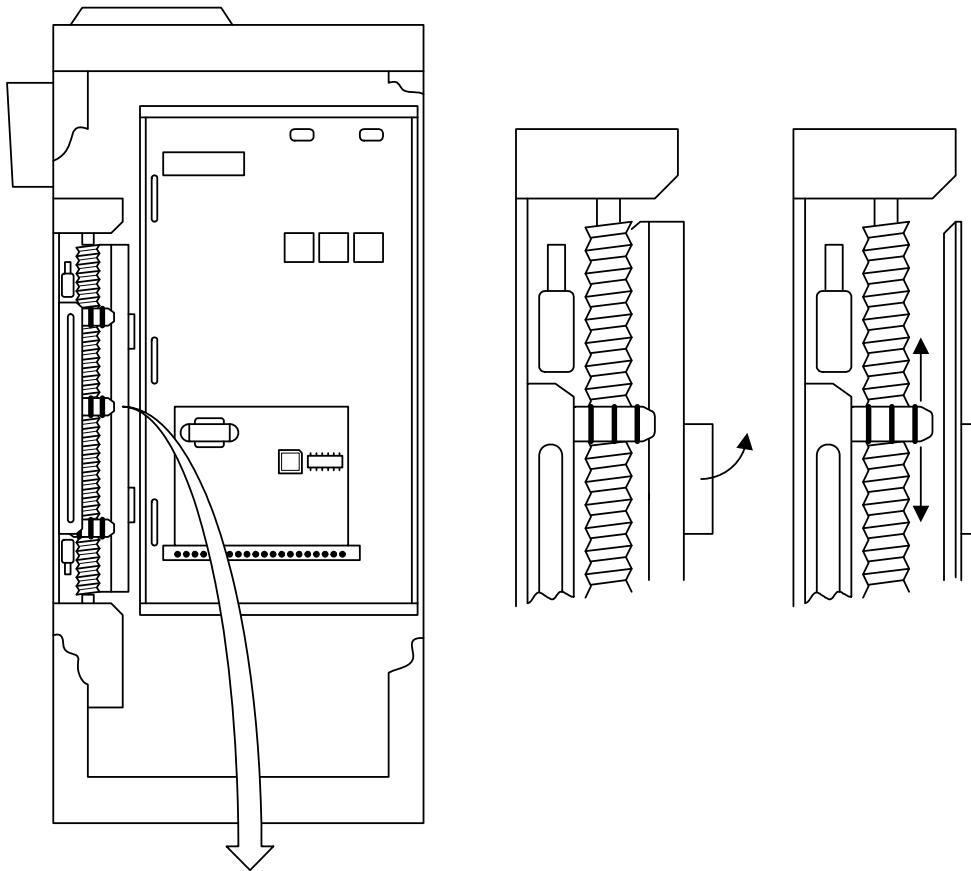

3.3.2 Slow-Down Switch Adjustment

The 9530 operator utilizes a pair of switches at the open and close positions. The first switch is the slow-down switch and the second switch is the limit switch. The slow-down switch is adjustable so that you can increase or decrease when the slow-down is initiated. For example, on heavy gates it is desirable to increase the slow-down distance to provide the operator more time to slow-down and stop the gate.

1. Turn power off.
2. Adjust the limit nuts as described in 3.3.1.
3. Loosen the nut that fastens the slow-down switch bracket to the partial open limit switch bracket. This will allow the slow-down switch assembly to move up or down approximately 3/4 inch. **DO NOT remove the slow-down switch assembly completely from the bracket it is attached to and then re-attach it in the larger slot on the bracket in an attempt to gain further adjustment. This will only cause mechanical damage to the switch assembly when the operator is activated.**
4. To increase the slow-down distance, move the slow-down switch away from the limit switch. To decrease the slow-down distance, move the slow-down switch closer to the limit switch.

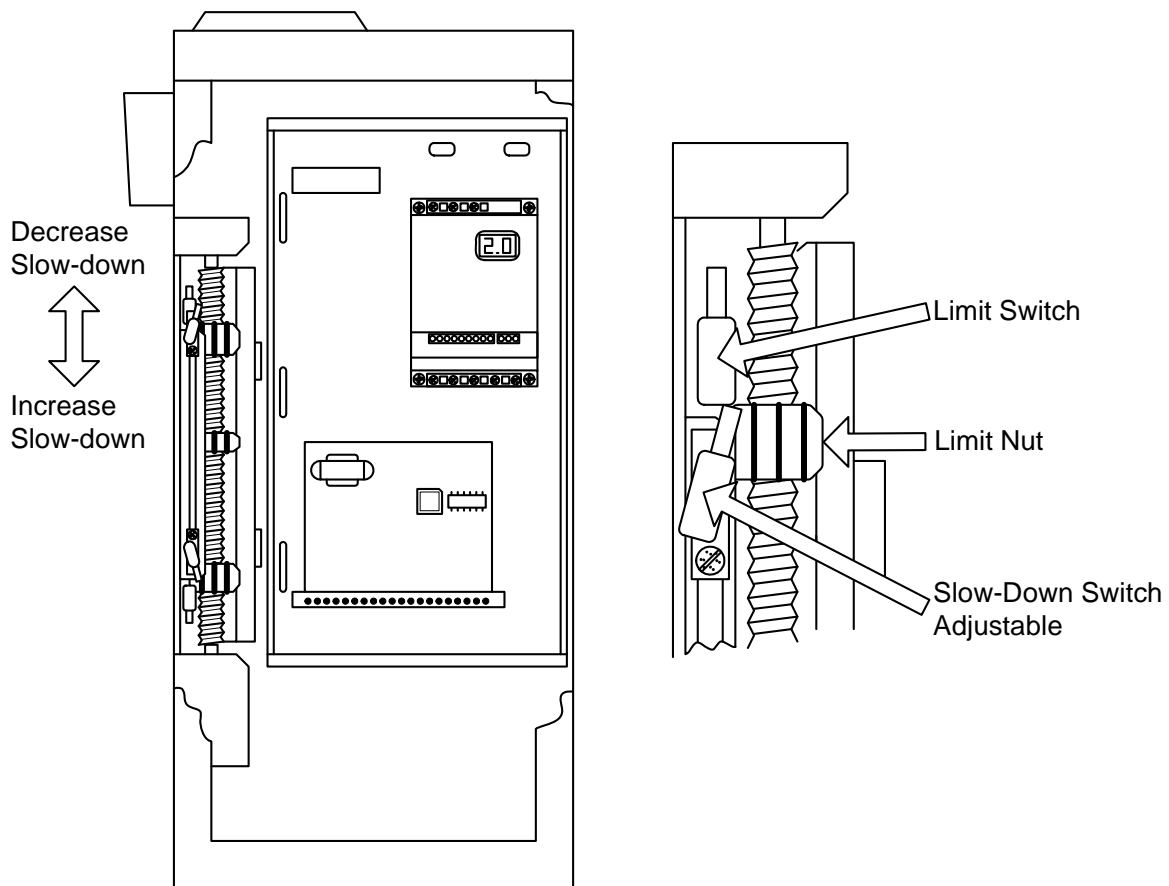

3.4 CURRENT SENSOR ADJUSTMENT

This vehicular gate operator is equipped with a motor current sensing system. This system will sense an obstruction in either the opening or closing gate cycles and will cause the gate to reverse direction should an obstruction be encountered. **For this system to function correctly, the gate must be properly installed and work freely in both directions. A good set of ball bearing wheels (or rollers) is essential for proper slide gate operation.**

WARNING! This current sensor is provided to reduce damage to the gate operator mechanics should an obstruction be encountered. It is not designed and it is not intended to be used as an inherent (Type A) entrapment sensing device.

1. Refer to section 3.6 before starting this adjustment.
2. Activate the gate operator by momentarily shorting terminal 1 and 5 with a 1-foot piece of 18 AWG wire. Be sure that the limit adjustment has been completed as described in section 3.3.
3. While the gate is running open, slowly rotate the open reverse sensitivity potentiometer clockwise until the gate reverses travel, then rotate the potentiometer 1/8 turn counter clockwise. Note: Rotating the sensitivity adjustment clockwise INCREASES the reverse sensitivity. Rotating this adjustment counter-clockwise DECREASES the reverse sensitivity. NOTE: After the gate has reversed, the operator will assume a "soft shutdown" making it necessary to initiate the cycle again by momentarily shorting across terminals 1 and 5 as in step 1.
4. While the gate is running closed, slowly rotate the close reverse sensitivity potentiometer clockwise until the gate reverses travel, then rotate the potentiometer 1/8 turn counter clockwise. Note: Rotating the sensitivity adjustment clockwise INCREASES the reverse sensitivity. Rotating this adjustment counter-clockwise DECREASES the reverse sensitivity. NOTE: After the gate has reversed, the operator will assume a "soft shutdown" making it necessary to initiate the cycle again by momentarily shorting across terminals 1 and 5 as in step 1
5. Operate the gate a few times to be sure that it cycles completely.
6. Place an immobile object along the path of the gate so that the gate will strike it while in the open cycle. The gate must reverse direction after striking the object. If it does not, increase the reverse sensitivity by turning the potentiometer 1/8 turn clockwise, then repeat this test. NOTE: After the gate has reversed, the operator will assume a "soft shutdown" making it necessary to initiate the cycle again by momentarily shorting across terminals 1 and 5 as in step 1.
7. Place an immobile object along the path of the gate so that the gate will strike it while in the close cycle. The gate must reverse direction after striking the object. If it does not, increase the reverse sensitivity by turning the potentiometer 1/8 turn clockwise, then repeat this test. NOTE: After the gate has reversed, the operator will assume a "soft shutdown" making it necessary to initiate the cycle again by momentarily shorting across terminals 1 and 5 as in step 1 to reactivate the automatic close timer.
8. You may have to repeat step 2 several times to find the correct sensitivity adjustment.

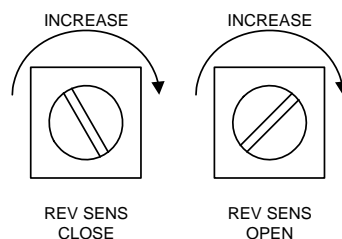

3.5 SPEED CONTROL

The 9530 is equipped with a speed control module that allows you to adjust the normal operating speed of the gate from 1/2 to 4 Ft./ Sec (Slow Speed Adjust). This speed is used when any of the open or close inputs on the main circuit board are activated.

The “Emergency Close” speed is adjustable from 1/2 to 6 Ft./Sec (High Speed Adjust). This speed is used when the “Emergency Close” input on the speed control module is activated.

The digital readout on the speed controller will display the gate speed (Ft/Sec) to assist in setting your desired speed.

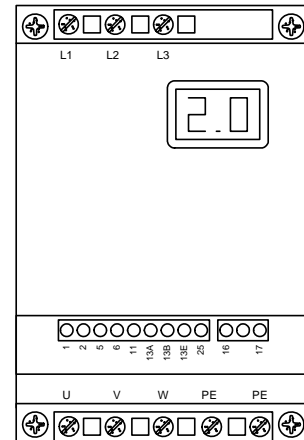
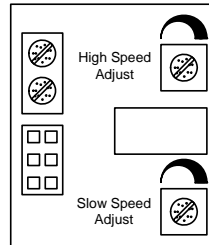

3.6 CURRENT SENSOR WIRING INFORMATION

This vehicular gate operator uses a current sensing device to detect any obstructions in the path of the opening or closing gate. The current sensor uses a sensing coil with a given number of turns through it to monitor the current flow into the operator. Each time the wire passes through the coil, it is considered a turn (see diagram below).

Voltage and Phase	Turns
208 Three Phase	5
230 Three Phase	6

The number of turns through the sensing coil is dependant on the operating voltage of the operator.

WARNING! This current sensor is provided to reduce damage to the gate operator mechanics should an obstruction be encountered. It is not designed and it is not intended to be used as an inherent (Type A) entrapment sensing device.

In general, light weight gates may require additional turns of wire through the ERD sensor, while heavier gates may require less turns. In addition, the speed of the gate can affect how the ERD sensor works. Gates running at a higher speed may require less turns of wire through the sensor.

CAUTION – HIGH VOLATGE: Be sure power is turned OFF before making any wire adjustments to the ERD sensor.

If you are setting the ERD sensitivity (section 3.4) and reach the full sensitive position without activating the reversing function, add an additional turn of wire through the current sensor. If you are decreasing the sensitivity and the gate will not run properly, reduce the number of turns through the current sensor.

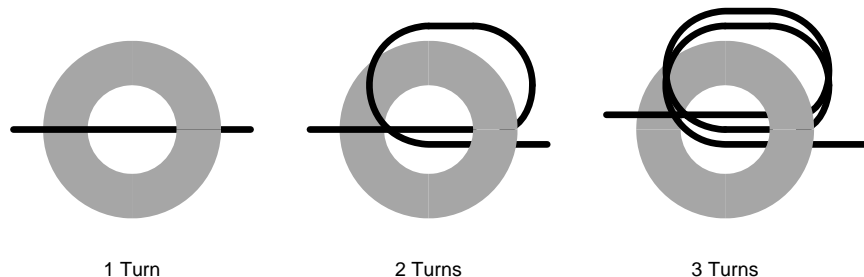

SECTION 4 – OPERATING INSTRUCTIONS

WARNING - To reduce the risk of injury or death:

1. READ AND FOLLOW ALL INSTRUCTIONS.
2. Never let children operate or play with gate controls. Keep the remote control away from children.
3. Always keep people and objects away from gate. **NO ONE SHOULD CROSS THE PATH OF THE MOVING GATE**
4. Test the operator monthly. The gate **MUST** reverse on contact with a rigid object or stop or reverse when an object activates the non-contact sensors. After adjusting the force or the limit of travel, retest the gate operator. Failure to adjust and retest the gate operator properly can increase the risk of injury or death.
5. Use the manual crank only when the gate is not moving and power has been shut-off.
6. **KEEP GATES PROPERLY MAINTAINED.** Read the owner's manual. Have a qualified service person make repairs to gate hardware.
7. The entrance is for vehicles only. Pedestrians must use separate entrance.
8. **SAVE THESE INSTRUCTIONS.**

4.1 POWER AND RESET SWITCHES

Open the power switch cover located on the side of the operator to access the MAIN POWER switch and the operator RESET switch.

- The RESET switch is used to turn off the entrapment alarm and to reset the operator after a hard shutdown has occurred.
- The AC POWER toggle switch turns power to the operator ON (toggle up) or OFF (toggle down).

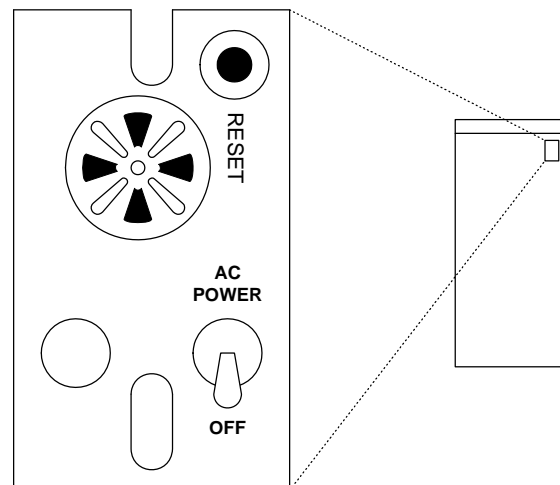

4.2 SHUTDOWN CONDITIONS

Under various conditions, the operator will assume either a soft or hard shutdown (alarm) condition. To determine what type of reset action is required, you will need to understand how the different obstruction conditions affect the gate operator.

4.2.1 SOFT SHUTDOWN

This occurs in various situations where the current sensor or secondary entrapment protection devices have been activated. In a soft shutdown condition, the operator will not respond to any input that was present when the current sensing device sensed an obstruction. If the gate stops at the open position, the operator will not respond to the automatic close timer.

- Example 1: A time clock keys the gate open in the morning and the current sensor senses an obstruction prior to the gate reaching the full open position. If the obstruction is sensed by the current sensor, the gate will reverse and run back to the closed position. The time clock input is still present, but the gate will not re-open.

NOTE: In some systems, the time clock input comes from the telephone entry system relay. This same relay may also provide open commands for a card reader, MicroPLUS transmitters and the visitor telephone entry. If so, these devices will also be disabled in a soft shutdown condition.

- Example 2: If the gate is closing and the current sensor device is activated, the gate will either stop or reverse and run back to the open position, depending upon if the secondary or current sensor device was activated. The automatic close timer will not close the gate.
- Example 3: Vehicle arrives at open loop and the gate runs towards the open position. The current sensor is activated. The gate reverses and runs back to the closed position. If the vehicle is still present at the open loop, a soft shutdown condition does not occur. The loop input provides an immediate reset of the operator and the gate will again run to the open position.

4.2.2 RESETTING A SOFT SHUTDOWN

In some conditions, a soft shutdown will reset as soon as the obstruction condition clears. For example, if a non-contact sensor (photo cell) is sensing an obstruction, the operator will stop the gate and assume a soft shutdown condition. When the photocell clears, the operator will return to normal operation.

When the operator is in a soft shutdown, activation of any "intended input" will reset the operator. An "intended input" includes any command, any standard safety input and any loop input. Activating any of these inputs will reset the gate. At that point the gate will return to normal operation. If the gate is open, the automatic close timer will then time out and close the gate.

4.2.3 HARD SHUTDOWN

A hard shutdown condition occurs when the current sensing system has sensed two consecutive obstructions before the gate reaches the full open or full closed position. **It can also be an indication that the gate is too heavy or that the gate hardware (wheels, rollers) is in poor condition and needs to be corrected.**

- Example: The gate is closing and the current sensing system senses an obstruction and causes the gate to reverse direction. As the gate begins to run in the open direction, a second obstruction is sensed prior to the gate reaching the full open position. Once the second obstruction has been sensed, the operator will stop, the audio alarm will be activated and all standard inputs are shut down (including open commands, safety commands, loop inputs, etc.).
- NOTE: The audio alarm will remain activated for a maximum of five minutes, or until the operator receives a reset input. The hard shutdown condition will remain in affect even if the audio alarm shuts off after five minutes.
- After 5 minutes, the audio alarm will “chirp” every 5 seconds. This indicates that the operator is in a hard shutdown condition and the reset switch must be activated to reset the operator and silence the alarm.

4.2.4 RESETTING A HARD SHUTDOWN

When the operator is in a hard shutdown condition (audio alarm activated or audio alarm “chirps” every 5 seconds), the only way to reset the gate operator and return it to normal operation is to activate the alarm reset input. An alarm-reset switch can be mounted external of the gate operator provided that it is installed in the line of sight of the gate and gate operator (see 2.6.1).

- Before resetting a hard shutdown, determine why the shutdown occurred. Inspect the gate for any obstructions along its path that could have activated the current sensing sensing system. Inspect the gate and gate hardware.
- NOTE: DoorKing operators have a built-in alarm reset push button mounted on the operator above the power ON-OFF toggle switch. Activating this button will return the gate operator to normal operation, but will not activate the gate operator.

Once the gate has been reset, an open or close command is needed to start the gate operator. Most activating commands will cause the gate operator to cycle to the open position. This includes activation of a key switch or open command and activation of an open loop. Activation of a close command will run the gate to the closed position.

- NOTE: The gate operator will not lose its limit settings when a hard shutdown occurs.

4.3 MANUAL GATE OPERATION

This operator is equipped with a manual system that will allow the gate to be cranked open in the event of a power outage or equipment failure.

NOTE: Never attempt to manually open any gate with an operator attached to it until you have verified that power to the operator has been shut-off.

The brake will automatically reset itself after power is turned back on.

- 1 Turn power OFF.
- 2 Using a flat head screwdriver, rotate brake release ¼ turn clockwise.
- 3 Insert crank handle to operate gate.

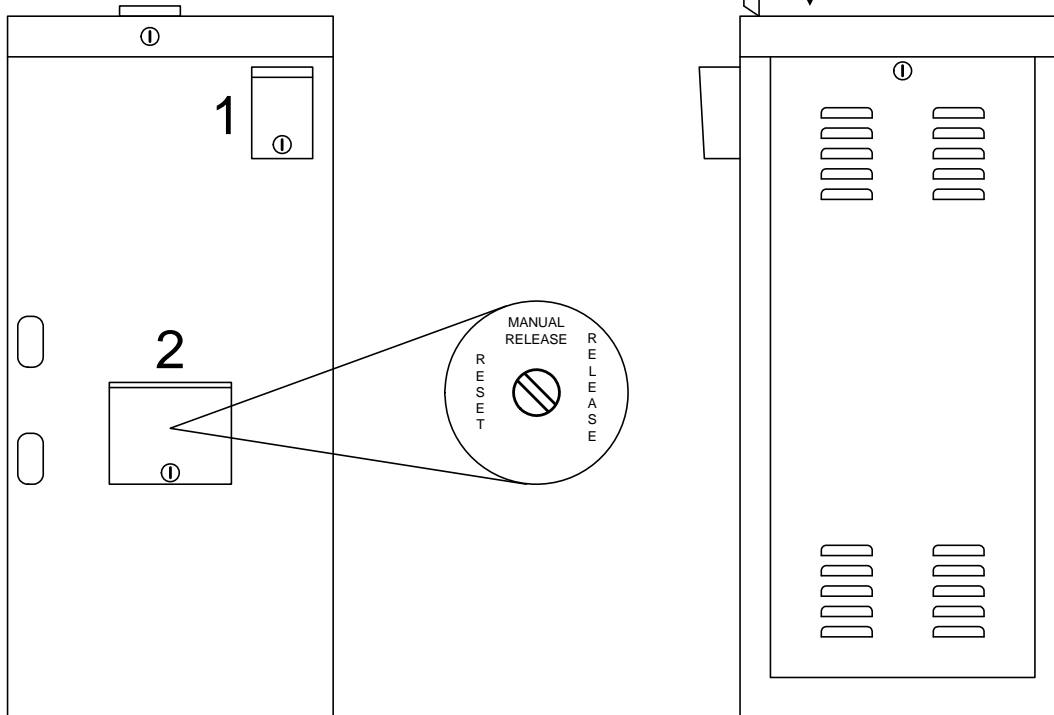

SECTION 5 – MAINTENANCE AND TROUBLESHOOTING

Inspection and service of this gate operator by a qualified technician should be performed anytime a malfunction is observed or suspected. High cycle usage may require more frequent service checks.

5.1 MAINTENANCE

When servicing the gate operator, always check any secondary (external) reversing devices (loops, photo eyes, etc.) for proper operation. If external reversing devices cannot be made operable, do not place this operator in service until the malfunction can be identified and corrected.

When servicing this gate operator, always turn power **OFF!!**

MAINTENANCE SCHEDULE		MONTHLY INTERVAL		
		3	6	12
Alarm	Activate the current sensing system by blocking the gate with a solid object. When the gate reverses, block the gate in the opposite direction prior to the limit being reached. The alarm should activate. Press the reset button to silence the alarm.	✓		
Chain	Check for sagging. Tighten if necessary.		✓	
Fire Dept.	Check emergency vehicle access device for proper operation.	✓		
Gate	Inspect for damage. Check gate wheels, rollers and guides for wear and grease if necessary.		✓	
Grease	Wheels and guide rollers if necessary.		✓	
Loop(s)	Check vehicular reverse and shadow loops for proper operation.	✓		
Current Sensing System	Check that the gate reverses on contact with an object in both the opening and closing cycles. Adjust reversing sensitivity if necessary.	✓		
Release	Check manual release for proper operation.	✓		
Secondary Reverse Device	Check that secondary (external) reverse device(s) stop or reverse the gate when activated.	✓		
Sprockets	Check setscrews for tightness.		✓	
Complete	Complete check of gate and gate operating system.			✓

5.2 OPERATOR DIAGNOSTICS

This gate operator is designed with built-in diagnostics that will alert you to potential or existing problems that the microprocessor has detected. Specific fault conditions are checked and the operator will signal that a fault exist through the built-in alarm.

Constant tone is heard when power is applied:

- This indicates that the limit switch wire harness is not connected to the circuit board. In this condition, the operator will not run and the tone will continue until the fault is corrected. Check to be sure that the limit switch plug is properly inserted into P2.

Constant tone is heard:

- This indicates that the operator is in a hard shutdown condition (section 4.2.3). The tone will continue to sound for five minutes, and then will beep once every five seconds. The operator-reset button must be pressed or power must be removed and then reapplied to return the operator to normal operation.

Short tone is heard every five seconds:

- This indicates that the operator has been in a hard shutdown condition in excess of five minutes. This will continue until the operator-reset button is pressed or until power is removed from the operator.

Operator runs for 1 second and stops, two short tones are heard:

- This indicates that there may be a fault with the current sensor circuit.

5.3 TROUBLE SHOOTING

Have a good VOM meter to check voltages and continuity. A Meg-Ohm meter capable of checking up to 500 meg-ohms of resistance is necessary to properly check the integrity of the ground loops. When a malfunction occurs, isolate the problem to one of three areas: 1) the operator, 2) the loop system, 3) the keying devices. **Use caution when checking high voltage terminals, motor capacitor and the motor.**

1. Check the input indicator LEDs. They should only come ON when a keying device (card reader, push button, etc.) is activated. If any of the input LEDs are ON continuously, this will cause the gate operator to hold open. Disconnect the keying devices one at a time until the LED goes OFF.
2. Check any external secondary entrapment protection devices. Any short or malfunction in these devices can cause the gate operator to stop or to hold open.
3. A malfunction in a loop or loop detector can cause the gate operator to hold open, or to not detect a vehicle when it is present over the loop. Pull the loop detector circuit boards from the loop ports on the operator circuit board. If the malfunction persists, the problem is not with the loop system. For more information on trouble shooting loops and loop detectors, refer to your loop detector instruction sheet and to the DoorKing Loop and Loop Detector Information Manual.
4. Check to be sure that there are no shorted or open control wires from the keying devices to the gate operator. If a keying device fails to open the gate, momentarily jumper across terminals 1 and 5 on the gate operator circuit board. If the gate operator starts, this indicates that a problem exist with the keying device and is not with the gate operator.
5. If a three-button control station (open-close-stop) is connected to this gate operator, check for proper wiring. Only a DoorKing three button control station (P/N 1200-006) can be used with this gate operator. Others will cause a malfunction.
6. Check the high voltage supply. A voltage drop on the supply line (usually caused by using too small supply voltage wires) will cause the operator to malfunction. Refer to the wire size chart in section 2.1.

TROUBLESHOOTING	
SYMPTON	POSSIBLE SOLUTION(S)
Operator will not run. Power LED is OFF.	<ul style="list-style-type: none"> • Check that power to the operator is turned ON. • Transformer may be overheated. Turn power off and allow board to cool for several minutes then retest. Check for low 120 VAC power and low voltage shorts. • Check for 120 VAC at terminals 18 and 19. If voltage measures 0, check power. If voltage measures OK, check the terminal strip or replace the circuit board.
Operator will not run. Power LED is ON.	<ul style="list-style-type: none"> • If a photocell is used as a secondary entrapment prevention device, check to be sure that the beam is not blocked. • Momentarily jumper terminal 1 to terminal 5. If the input LED does not come ON, check the terminal strip or replace the circuit board. If LED does come ON, proceed to next steps. • Be sure that the chain is not too tight. A too tight chain may cause the operator to stall. • Turn power switch OFF and remove the control board. • Place a jumper wire from terminal 18 terminal 17. CAUTION – HIGH VOLTAGE. Turn the power switch on. The motor should run. Turn the power switch off and remove the jumper. • Place a jumper wire from terminal 18 to terminal 16. CAUTION – HIGH VOLTAGE. Turn the power switch on. The motor should run in the opposite direction. Turn the power switch off and remove the jumper. • If the motor runs in both steps above, replace the control board. If the motor does not run, or runs in only one direction, problem can be a bad motor, motor capacitor, wire connections from the control board to the motor or a bad control board.

Gate opens a short distance, then stops and reverses.	<ul style="list-style-type: none"> • Disconnect the gate from the gate operator and check that the gate slides freely without any binding. • Re-adjust the open reverse sensitivity. • Replace the circuit board.
Gate opens but will not close.	<ul style="list-style-type: none"> • Check the input LEDs. Any ON will hold the gate open and indicates a problem with a keying device. • Check the secondary safety devices. Any activated will hold the gate open and indicates a problem with the safety device. • Check the loop detectors. Any activated can hold the gate open and indicates a problem with the loop detector or ground loop. • Operator may be in a "soft shutdown." Activate any keying device to determine if operator returns to normal operation. • If automatic close is desired, be sure SW-1, switch 2 is ON. • Check motor as described on previous page.
Gate closes but will not open.	<ul style="list-style-type: none"> • Operator may be in a "soft shutdown." Check input LED on terminal 5. If it is ON, momentarily disconnect, then re-connect the wire going to the terminal. Operator should open. • Check to be sure that the operator is running in the proper direction. Turn power OFF, and then back ON. Activate a keying device. Operator should run in the open direction. If operator runs in the close direction, turn power OFF and change direction switch SW-1, switch 1. Go to above section if operator now opens but will not close. • Be sure that the respective LED on the control board lights when the keying device connected to the respective terminal is activated. If LED does not light, momentarily place a jumper wire from terminal 1 to the input terminal being checked. If LED lights and gate opens, problem is with the keying device. If LED does not light, replace control board. • Check motor as described on previous page.
Gate starts to close, then reverses to open.	<ul style="list-style-type: none"> • Re-adjust the close reverse sensitivity. • Disconnect the gate from the operator and check that the gate operates freely without any binding. • Check the loop detector LEDs and input LEDs. Any that flash ON will cause the gate to reverse. • Replace the circuit board.
Gate closes and then re-opens.	<ul style="list-style-type: none"> • Check for any input or loop detector LEDs that are ON. • Check that the operator is running in the proper direction (see "gate closes but will not open" above).
Entrapment alarm is sounding. Operator will not run.	<ul style="list-style-type: none"> • Operator is in a "hard shutdown" condition. Reset switch must be activated to return operator to normal operation. • Check gate and gate hardware for any binding – correct where necessary. • Gate may be too heavy.
Entrapment alarm sounds a short beep every 5 seconds.	<ul style="list-style-type: none"> • Operator has been in a "hard shutdown" condition in excess of 5 minutes. Reset switch must be activated to return operator to normal operation.
Entrapment alarm activates when power is applied and operator will not run.	<ul style="list-style-type: none"> • The limit switch wire harness is not plugged into the circuit board. Check that the limit switch connector is properly plugged into P2 on the circuit board.
Operator runs for 1 second and stops, two short beeps are heard.	<ul style="list-style-type: none"> • There may be a problem with the current sensor on the circuit board. Replace the circuit board.

5.4 ACCESSORIES

The following accessory items can be used with the model 9210 / 9230 slide gate operator.

Contact Sensor	Contact sensors for use as a secondary entrapment protection device. Miller Edge, Inc. ME120, ME123, MG020, MGR20, MGS20
Photo Cell	Non-contact (photo cells) sensors for use as a secondary entrapment protection device – Listed to UL 325. Infrared Thru-Beam with hood and built-in heater. 165-foot range. P/N 8080-010 Photo-Reflective. 30-foot range. P/N 8080-011 Infrared Thru-Beam. 65-foot range. P/N 8080-031 Polarized Photo-Reflective. 35-foot range. P/N 8080-030
Loop Detector	Detectors plug directly into ports on circuit board simplifying wiring. P/N 9410-010 - Single channel detector. P/N 9409-010 - Two channel detector
Loop Wire	18 AWG loop wire with XLPE insulation is ideal for ground loops. Available in 500 and 1000 foot rolls with red, blue or black insulation.
Pre-Fab Loops	Prefabricated ground loops. 24-foot circumference with 50-foot lead-in. Available in yellow, red or blue jackets. Not for use in asphalt roadways.
Loop Test Meter	Meg-ohm meter checks the integrity of ground loops. P/N 9401-045
Control Station	Three button interior and exterior control stations provide manual open-close-stop gate operation. P/N 1200-006 – Exterior / Interior P/N 1200-007 - Interior
Time Clock	7 day and 365 day time clocks can be used to automatically open gate at pre-set time and days. Compact clock fits inside the operator. P/N 2600-791 – 7-day clock. P/N 2600-795 – 365-day clock.
Surge Devices	High and low voltage surge suppressers help prevent circuit board failure caused by lightning strikes and power surges. P/N 1876-010 - High Voltage. P/N 1878-010 - Low Voltage.
Gate Scale	Use to test ft/pounds required to move gate. P/N 2600-225
Speed Bumps	Prefabricated six-foot speed bump reduces traffic speed through gate system. P/N 1610-150
Mounting Stand	Heavy-duty pedestal mounting stand for the 9210 operator. P/N 9200-135
Remote Reset	Remote reset control station includes both audio and visual alarms to indicate gate operator is in a hard-shutdown condition. Also provides a reset button to reset the operator. P/N 1404-080
Traffic Signal	Red / Green traffic signal is synchronized with the movement of the gate and alerts drivers when it is safe to proceed. P/N 1603-208

208 VAC, 3-Phase Variable Speed

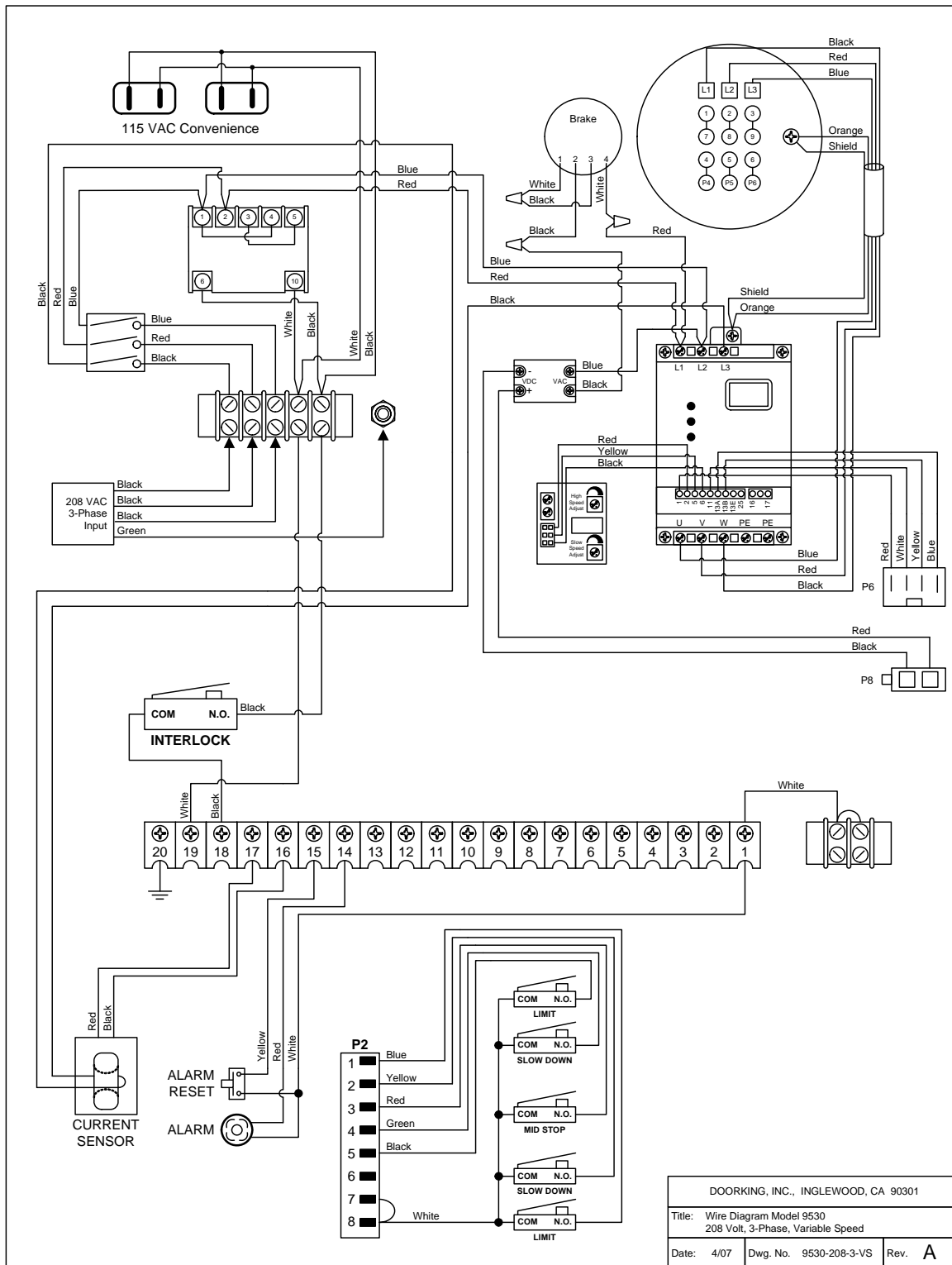

230 VAC, 3-Phase Variable Speed

