



Instructions for RS485 Keypad

The RS485 Keypad is designed to work with the Access Plus system. See reverse side for wiring information.

Setting the Keypad Address

The only valid device addresses that can be used with the Access Plus system are 003 through 008. Each device (keypad, card reader, RF receiver) must have a unique address and the addresses must start with 003 and continue in sequence. The type of device does not matter, only the address matters.

Switch SW2 and rotary switches SW3 and SW4 are used to set the address on the 1513 keypad. Since the address on the device must be set between 003 and 008, SW2 is left in the OFF position and SW3 is set to 0. You only need to set SW4 for the address of the device (003 – 008).

In the example at right, the receiver address is set for 003.

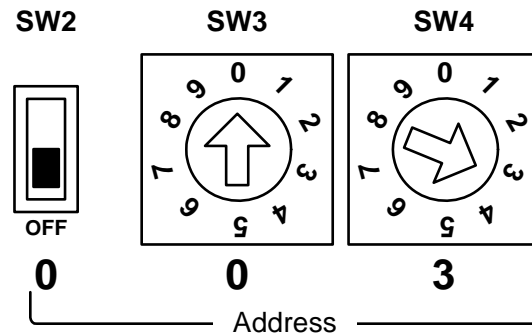

Each device (card reader, keypad and/or receiver) must have a unique address and continue in sequence. Do Not Skip an address.

The order in which the device is connected to the Access Plus controller does not matter. What is important is that the address must be in sequence starting with 003.

The LED on the circuit board is for troubleshooting

1. If the LED is continuously ON, this indicates a good connection to the controller.
2. If the LED Flashes in inconsistent patterns or is OFF, this could indicate a problem with the RS485 communication (duplicate addresses, loose wire, no proper grounding, etc.).

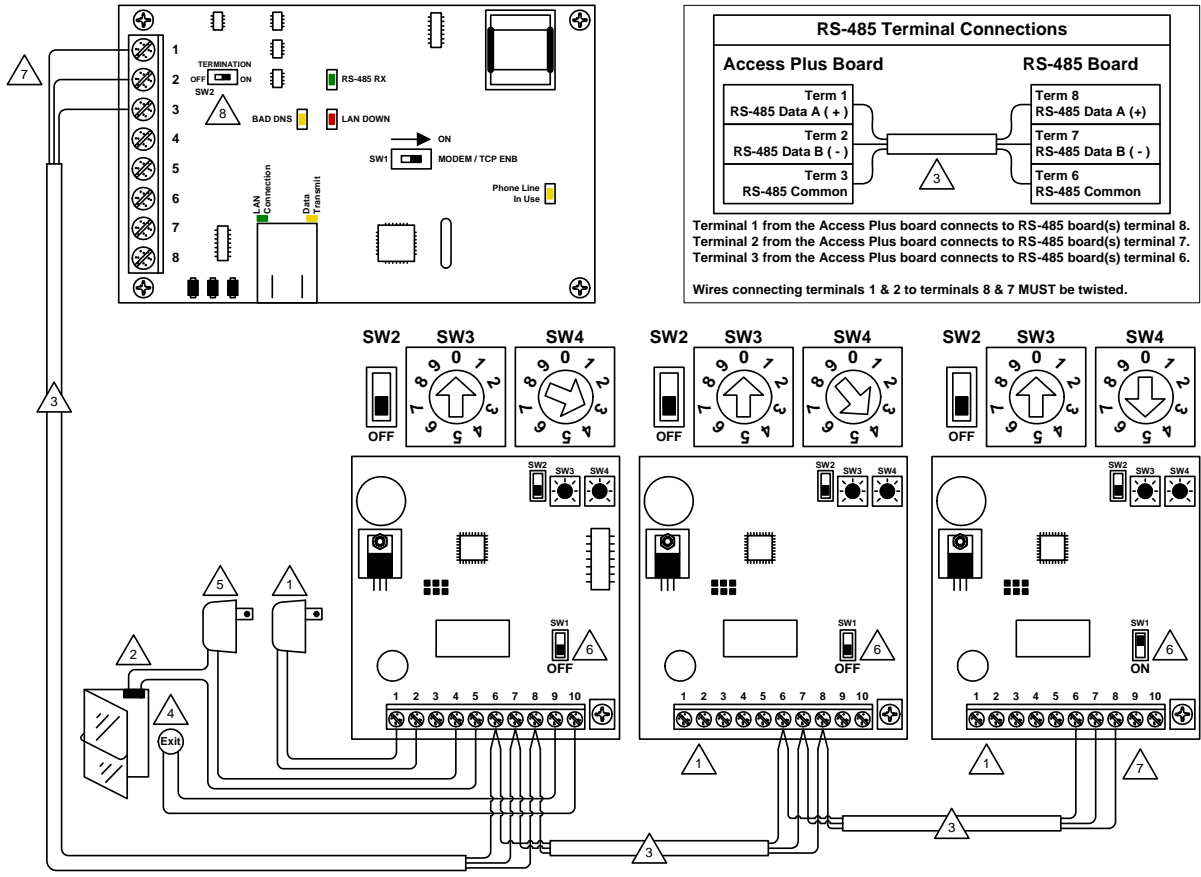

RS-485 Terminal Connections

Access Plus Board	RS-485 Board
Term 1 RS-485 Data A (+)	Term 8 RS-485 Data A (+)
Term 2 RS-485 Data B (-)	Term 7 RS-485 Data B (-)
Term 3 RS-485 Common	Term 6 RS-485 Common

Terminal 1 from the Access Plus board connects to RS-485 board(s) terminal 8.
Terminal 2 from the Access Plus board connects to RS-485 board(s) terminal 7.
Terminal 3 from the Access Plus board connects to RS-485 board(s) terminal 6.

Wires connecting terminals 1 & 2 to terminals 8 & 7 MUST be twisted.

Terminals	
1	12-24 Volt AC/DC (-)
2	12-24 Volt AC/DC (+)
3	Relay Normally Open (N.O.)
4	Relay Normally Closed (N.C.)
5	Relay Common
6	RS485 Gnd
7	RS485 Data (B)
8	RS485 Data (A)
9	Request to Exit Com
10	Request to Exit Input

- 1 12 – 24 Volt, AC or DC power. Do not power from the Access Plus controller. Must be supplied with its own power source as shown.
- 2 Magnetic locks are wired to the Normally Closed relay contacts. Electric strikes are wired to the Normally Open relay contacts.
- 3 The wires connected from the Access Plus board (terminals 1 & 2) to the RS-485 boards (terminals 8 & 7) MUST be twisted. We recommend that you use Cat5e cable. Use one pair to these terminals and then one wire from one of the other pairs to connect terminal 6. If wiring will be outdoors or underground, use Cat5e Gel Filled (flooded) UV Resistant Direct Burial Cable. Match terminals on RS 485 board (i.e., term 6 to term 6; term 7 to term 7; term 8 to term 8).

- 4 A switch closure across terminals 9 & 10 will activate the relay for its programmed strike time.
- 5 Lock power. Do not power magnetic locks or electric strikes from the RS-485 circuit board power source. Locks must be powered from their own source.
- 6 SW 1 is in the OFF position for middle units, and in the ON position for end units. If terminals 6, 7 & 8 have two wires connected to them, the SW 1 must be OFF. If terminals 6, 7 & 8 have only a single wire connected, the SW 1 must be ON.
- 7 Maximum distance from end to end is 4000 feet in a Daisy Chain format as shown in the diagram at right.
- 8 If the AP Controller is an END unit, then SW 2 is ON. If the AP Controller is a middle unit, then SW 2 is OFF.

