



Owner's Manual

Model 2348 Elevator Control Boards

DoorKing, Inc.
120 Glasgow Avenue
Inglewood, California 90301
U.S.A.
Phone: 310-645-0023
Fax: 310-641-1586
www.doorking.com

Use this manual with the following models only.

Elevator Control boards 2348-010 Rev A or higher.

DoorKing, Inc. reserves the right to make changes in the products described in this manual without notice and without obligation of DoorKing, Inc. to notify any persons of any such revisions or changes. Additionally, DoorKing, Inc. makes no representations or warranties with respect to this manual. This manual is copyrighted, all rights reserved. No portion of this manual may be copied, reproduced, translated, or reduced to any electronic medium without prior written consent from DoorKing, Inc.

Wiring charts on pages 38-51 may be copied as necessary.

Table of Contents

Section 1 – Introduction

1.1	General Information.....	7
1.2	Visitor Elevator Control	
1.2.1	Lobby Hall Up Call On.....	8
1.2.2	Lobby Hall Up Call Off.....	8
1.3	Resident Elevator Control	9
1.3.1	Programming Resident Floor Control Relay Time	9
1.4	System Requirements	10

Section 2 –Control Cabinet Installation

	General Information.....	11
2.1	Large Housing	12
2.2	Small Housing	13

Section 3 – Set-up Information

3.1	Block Diagram	15
3.2	Board Set-up	16
3.2.1	Elevator Shaft Identification	16
3.2.2	Floor Identification	16
3.2.3	Relay Settings	17
3.2.4	Lobby Hall Up Call Relay	17
3.3	Switch Settings & Description	18

Section 4 – Wiring Information

4.1	General Information.....	19
4.2	Control Board Terminal Identification	20
4.3	Power Wiring Block Diagram.....	22
4.4	Control Wiring	
4.4.1	Wiegand Wiring.....	23
4.4.2	Floor Control Relay Wiring	23
4.4.3	Lobby Hall Up Call Relay	24
4.4.4	Ground Floor Detect Switch	24
4.4.5	Resident Access Device	24
	Wiring Diagram	25
	Detail Wiring Diagram.....	26

Section 5 – Elevator Control

	Common Oversights	27
	Software Programming.....	28

Section 6 – Trouble Shooting

6.1	General Trouble Shooting	35
6.2	Programming Trouble Shooting Aids	
6.2.1	Automatic Test #1	36
6.2.2	Manual Test # 2	36
6.3	Appendix.....	37
	Relay Wiring Identification Sheets.....	38

Section 1 – Introduction

DoorKing's Model 2348-010 Elevator Control System provides complete elevator security and is used to (1) restrict which floors visitors may have access to via the elevator(s) after they have been granted access by a building resident, and (2) restrict which floors residents may have access to via the elevator(s). Elevator control is typically used in high rise apartment building applications that are equipped with this option and a DoorKing Model 1833, 1835 or 1837 Telephone Entry System, or the DoorKing Model 1838 Multi-door Access Control System. This system also requires the installation of an access device (card reader) in the elevator car to enable building residents to activate the floor buttons according to the security level assigned to them.

1.1 General Information

Up to eight (8) elevators may be controlled by up to eight (8) DoorKing Access Control Systems (1833, 1835, 1837, 1838) at four (4) entrances. Typically, a telephone entry system is installed at the building entrance. The 2348-010 elevator control board(s) is located and installed close to the elevator electronic control panel. A three conductor wire connects the 2348-010 board to the telephone entry system. Resident access to different floors in the building is controlled by an access device (card reader) installed in the elevator car and connected to the telephone entry system (or to a Tracker expansion board) by routing the wiring along with the elevator car electrical umbilical cable.

The elevator control system is able to restrict elevator button operation by interrupting the button wiring between the elevator car and the elevator control electronics. The elevator car floor button wiring is routed through the relays on the elevator control board before being connected to the elevator electronics. In this manner, the 2348-010 elevator control system may either open or close the wiring to the floor buttons in the elevator car upon command, and thus either disable or enable the desired floor button(s) for a programmed period of time.

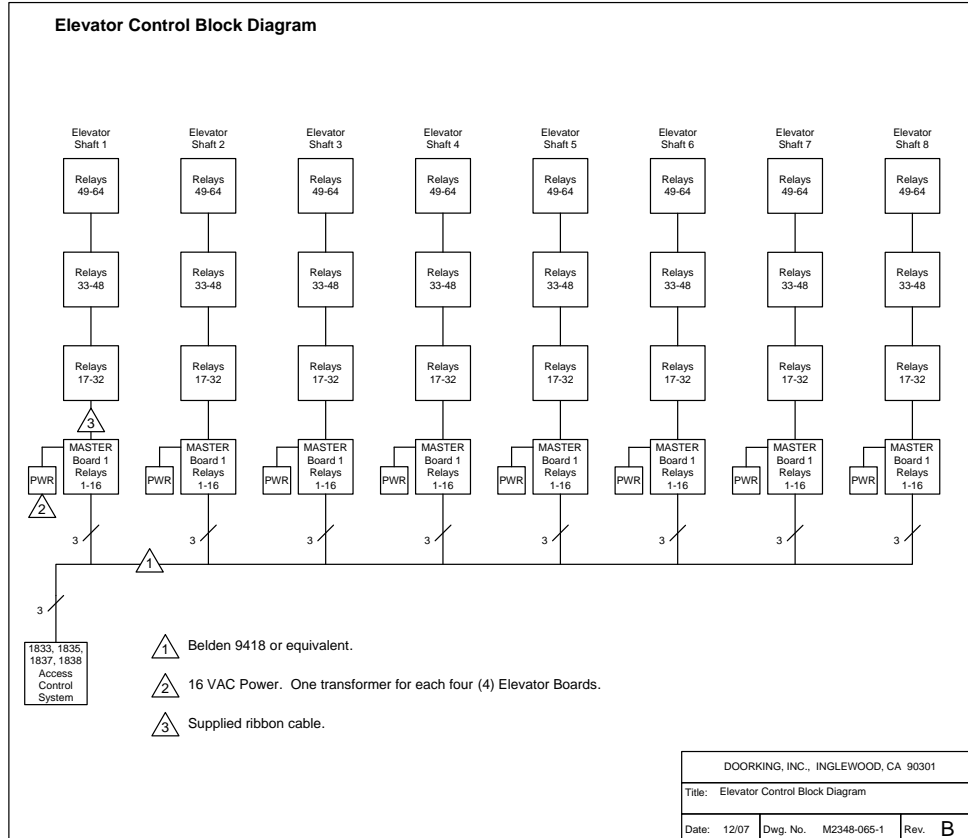

Figure 1

1.2 Visitor Elevator Control

When a visitor calls a resident via the telephone entry system and the resident grants the visitor access, data is sent from the telephone entry system to the 2348-010 elevator control board. Upon receiving this data, the elevator control board will respond in two different manners depending on the setting of SW2, switch 8.

1.2.1 Lobby Hall Call On

If SW2, switch 8 is in the OFF position, a "Lobby Hall Up Call" relay on the elevator control board will activate and call the elevator to go to the lobby or ground floor. This is accomplished by wiring the output of the lobby call relay in parallel to the ground floor button in the elevator electronics panel. Once the elevator reaches the ground floor, a ground floor detect switch must signal the 2348-010 board that the elevator has arrived. This signal is in the form of a switch closure across terminals 17 and 18 and may be available from existing hardware in the elevator electronics panel. Once the 2348-010 board receives this elevator detect signal, the floor button that the resident who granted the visitor access resides on, will become "live" for a period of time that has been set in the DoorKing Remote Account Manager software. Only this floor button will work when the visitor enters the elevator.

Using the lobby hall call feature is desirable in that the timer for the floor button does not become active until the elevator reaches the lobby or ground floor. For example, if the timer was set in the software to activate the floor button for one minute, the one minute timer will not start until the elevator car reaches the ground floor. This would assure that there is ample time for the visitor to walk to the elevator and press the respective floor button.

1.2.2 Lobby Hall Call Off

If SW2, switch 8 is in the ON position, the "Lobby Hall Up Call" relay on the 2348-010 board does not operate. When the visitor is granted access, the floor button that the resident who granted the visitor access resides on immediately becomes "live" for the period of time that has been programmed in the software. In this mode, the 2348-010 board does not call the elevator to the lobby or ground floor. This would require the visitor to press the elevator call button in the lobby to call the elevator to the ground floor.

It is important to note that if the 2348-010 control board is used in this manner, the floor button in the elevator car becomes "live" immediately after the visitor is granted access and the time period that the button is "live" begins immediately. Because of this, the time period that the button is "live" must be set for an adequate amount of time to allow the elevator to reach the ground floor from the highest floor, and allow the visitor time to walk to the elevator. This time is set in the DoorKing Remote Account Manager software.

1.3 Resident Elevator Control

When elevator control is in use, an access device such as a card reader must be installed in the elevator car to allow residents access to the floors in the building. Residents can be restricted to certain floors, or allowed access to all floors. These restrictions are dependent on the security level assigned to the resident and are programmed in the DoorKing Remote Account Manager software.

When a resident enters the elevator car, they insert their access card into the card reader. This is necessary because the floor buttons in the elevator remain "dead" until a command is received by the 2348-010 board to turn them on. Depending on the security level assigned to them, the floor button(s) in the elevator car will become "live."

The time interval that the button(s) is "live" is dependant on the revision level of the **1830 series telephone entry/access controller circuit board**, not the 2348 elevator control board. Refer to the table below.

Controller Circuit Board	Revision Level	Time Interval
1833	A - E	7 Seconds
1835		
1837		
1833	F - Higher	Programmable from 1 to 254 seconds
1835		
1837		
1838	A - C	7 Seconds
1838	D - Higher	Programmable from 1 to 254 seconds

Table 1

1.3.1 Programming Resident Floor Control Relay Time

The following programming sequence can only be performed at the telephone entry / access system controller keypad. The resident elevator button relay time interval cannot be programmed via the Remote Account Manager software. The maximum time that can be entered is 254 seconds.

Factory setting = 007

1. Press * **3 6** and then enter the four digit master code _ _ _ _ (beep). The display on the 1835 and 1837 systems will read: RES ELE TIME xxx SEC
2. Enter the relay time in seconds (001 – 254) _ _ _ then press * (beep).
3. Press **0 #** together to end this programming sequence (beeeeeep).

1.4 System Requirements

The maximum number of elevator control systems that can be controlled from a DoorKing access control system (1833, 1835, 1837, 1838) is eight. That is eight elevator cars (shafts) with each car serving up to 64 floors. Each 2348-010 elevator control board can control up to 16 floors in a single shaft, therefore a single elevator serving 64 floors requires the use of four (4) 2348-010 boards. If two elevator cars (shafts) need to be controlled, with each car serving 32 floors, a total of four (4) 2348-010 boards would be required - two for each elevator car (shaft).

The table below determines the number of 2348-010 boards required to control the elevator system, depending on the number of cars (shafts) and floors that are to be serviced.

Floors	Elevator Shafts							
	Car 1	Car 2	Car 3	Car 4	Car 5	Car 6	Car 7	Car 8
1-16	1	2	3	4	5	6	7	8
17-32	2	4	6	8	10	12	14	16
33-48	3	6	9	12	15	18	21	24
49-64	4	8	12	16	20	24	28	32

Table 2

The 2348-010 boards are housed in either a small (1816-102) or large (1816-100) cabinet. The small cabinet will hold two 2348-010 boards, while the large cabinet will hold up to four boards. Each elevator shaft requires either a small or large cabinet depending on the number of 2348 boards that are required for the shaft.

The DoorKing elevator control system can only be used with a DoorKing model 1833, 1835 or 1837 telephone entry system, or with the DoorKing model 1838 multi-door access control system. A card reader (or other access device) must be installed in the elevator car to allow building residents access to floors as defined within the security level assigned to them. The system must be programmed with a PC using the DoorKing Remote Account Manager for Windows software, version 5.0 or later. Tracker expansion boards may be required depending on the number of doors and elevator cars being controlled by the system.

Section 2 - Control Cabinet Installation

Installation of the 2348-010 elevator control board(s) and cabinet(s) should be coordinated with the elevator service company. The cabinets should be installed in close proximity to the elevator electronic control panel so that wiring between the elevator electronic control panel and the 2348-010 board(s) is simplified. 110 VAC power must be available nearby to power the transformer(s) that will supply 16 VAC power to the 2348-010 board(s). One 16 VAC power transformer is required for each elevator car (shaft) controlled.

1. Open the cabinet and remove any ribbon cables from the 2348-010 board (systems with two or more boards only).
2. Remove the four screws from each corner of the board and then remove the board from the cabinet. **CAUTION: Touch a proper ground with your hands before removing the board(s) from the cabinet.** This will discharge any static electricity and prevent electrostatic discharge damage to the board.
3. Mount the cabinets. Each cabinet has four mounting holes located in the corners. Be sure that the mounting screws do not protrude into the cabinet in such a way that they can cause a short to the back of the 2348-010 board.
4. Make any conduit connections at this time.
5. Clean out the cabinet being sure that any metal shavings are removed from the cabinet.
6. Re-install the 2348-010 board(s) and the ribbon cables.

2.1 Large Housing

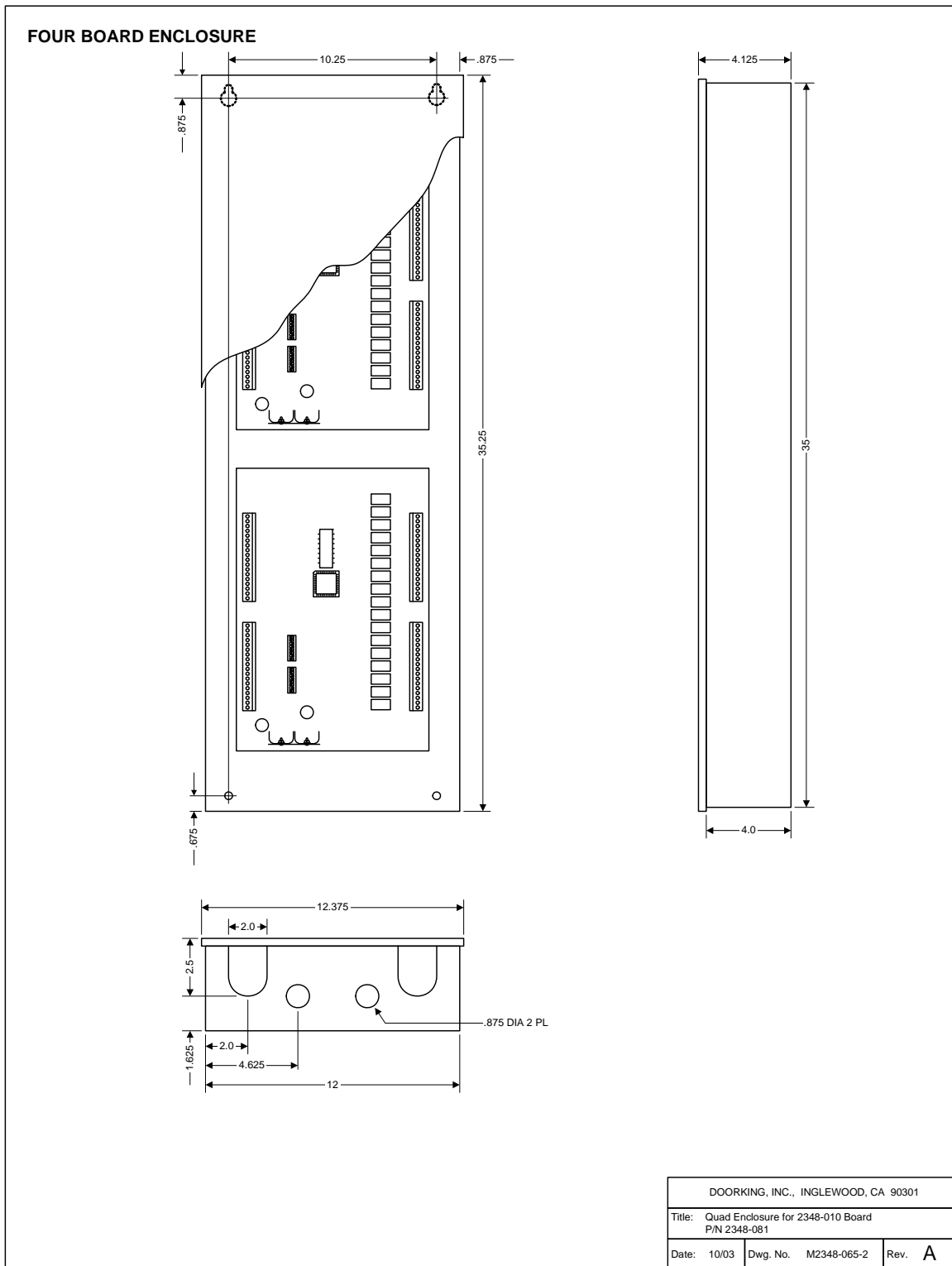

Figure 2

2.2 Small Housing

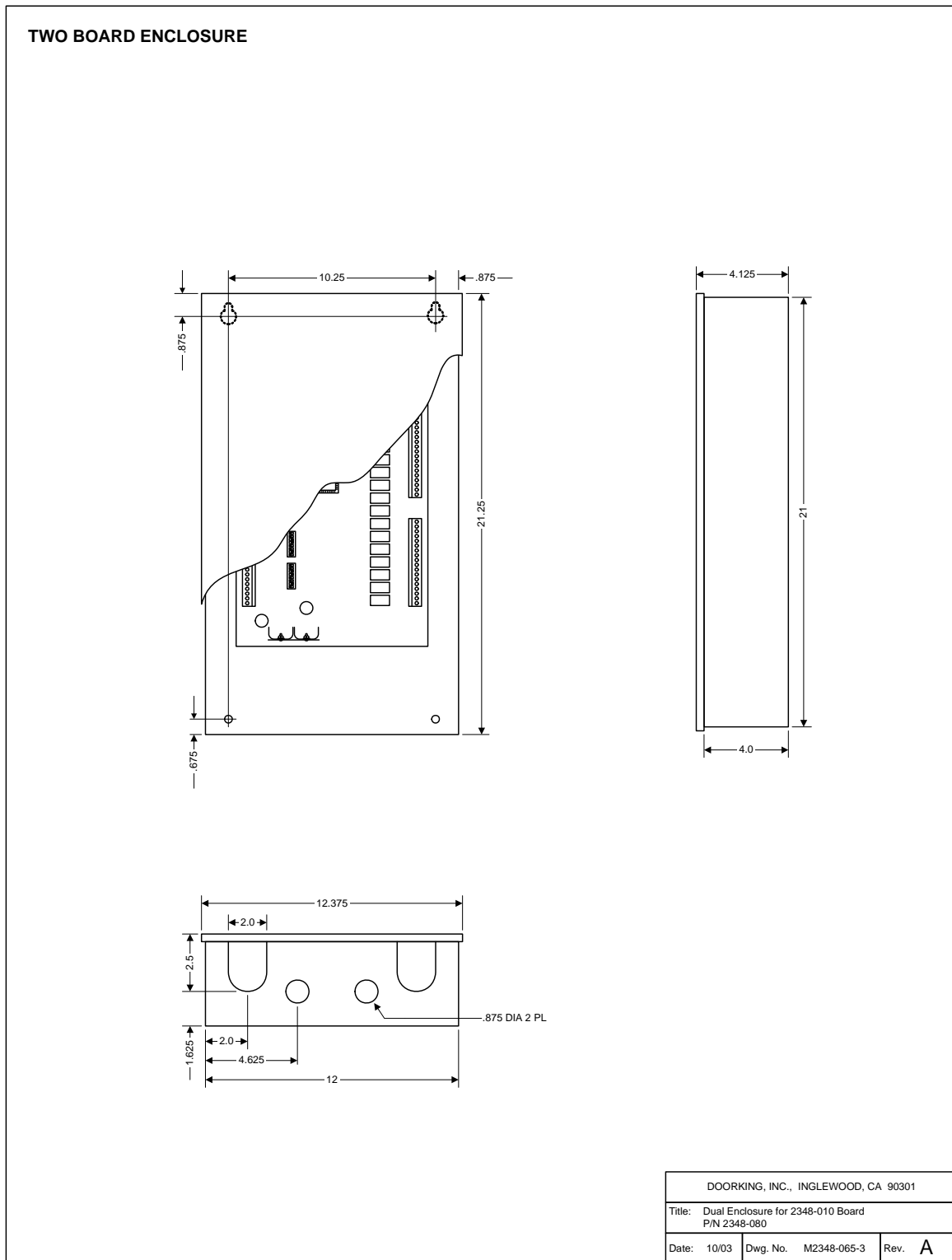

Figure 3

Section 3 – Set-up Information

This chapter will describe how to set-up the 2348-010 elevator control board for different modes of operation, and how to identify each board and which elevator and floors the board is controlling to the access system. This is determined by the switch settings of SW1 (top) and SW2 (bottom) on each of the 2348-010 boards. The floor relays on the board can be set to operate as either normally closed or normally open devices by placement of the relay jumpers on either the N.O. or N.C. pins next to the corresponding relay.

3.1 Block Diagram

Each elevator control board has 16 floor relays. One elevator shaft can consist of four (4) 2348-010 elevator boards to control up to 64 floors (16 x 4). The elevator boards are connected to each other via a ribbon cable. The elevator board that is connected directly to the access system is designated as the **MASTER** board - therefore each MASTER board can have up to three (3) additional 2348-010 boards connected to it via the ribbon cable. Each access system (1833, 1835, 1837, 1838) can have up to eight (8) MASTER 2348-010 boards connected to it, with each master controlling an additional three (3) boards. Therefore, the access system can accommodate up to eight (8) elevator shafts with each shaft accommodating up to 64 floors.

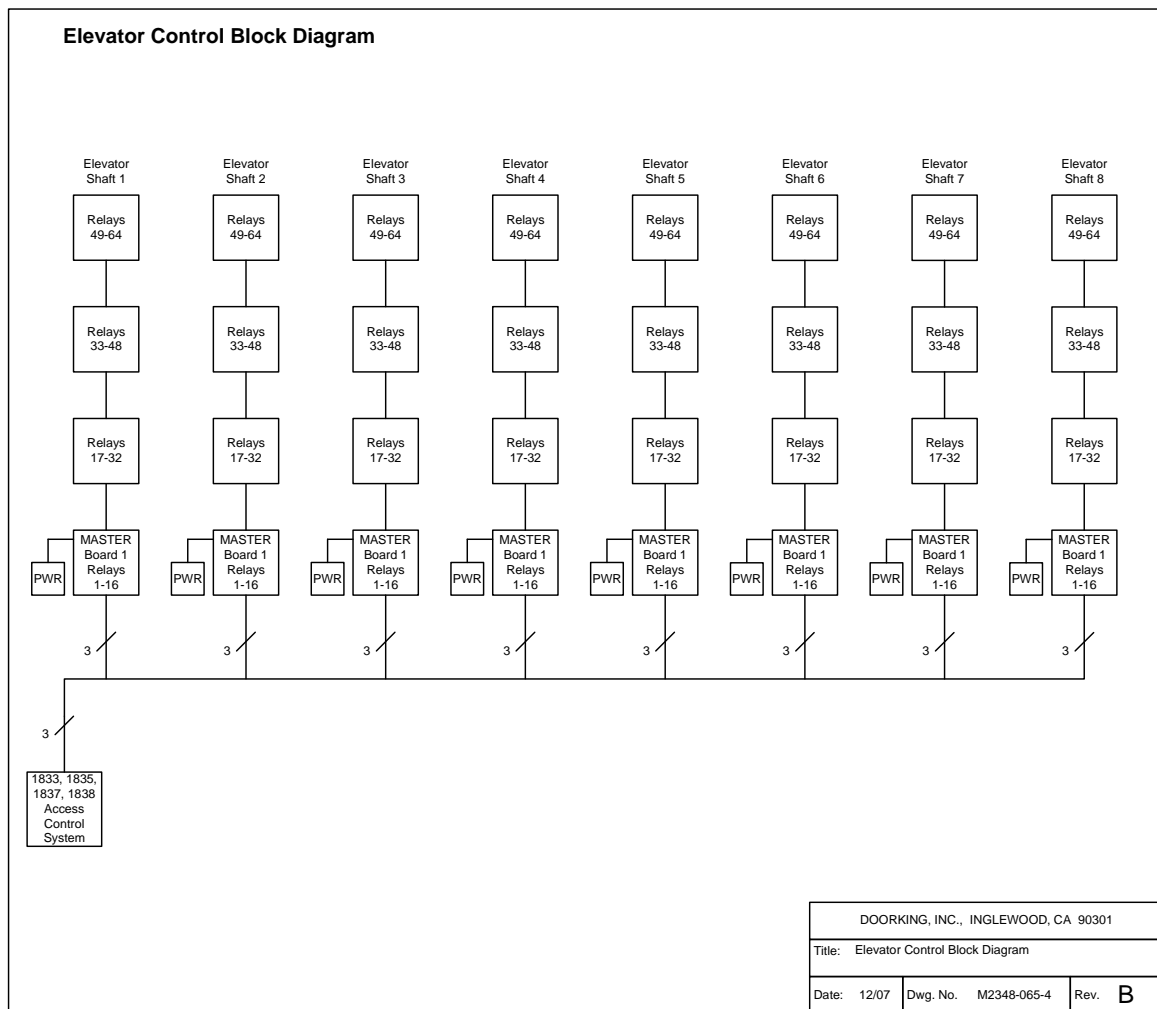

Figure 4

3.2 Board Set-up

The 2348-010 elevator boards must be set to identify to the access control system which elevator shaft that it is in, and which floors in the elevator shaft that it is controlling. This programming function is accomplished by the two DIP switches on the elevator control board, with each DIP switch having eight (8) switches in them. The top switch is designated as SW-1 and the bottom switch is designated as SW-2. **NOTE: Switches 4-7 on SW-1 and switches 3-7 on SW-2 are spares and are not used. Leave these switches in the OFF position.**

3.2.1 Elevator Shaft Identification

Each MASTER board must be set to identify which elevator shaft that it is controlling (shaft 1, 2, 3, 4, 5, 6, 7 or 8). The shaft setting is set by switch SW-1, switches 1, 2 and 3 (Table 3). The MASTER board is the board that has 16 VAC power connected to it and is connected to the access control system elevator terminals and receives weigand data from the access control system. There can only be one MASTER board per shaft. If there is more than one MASTER board in the system (two or more elevator shafts), it is very important that these switches be set correctly.

NOTE: SW-1, switches 1, 2 and 3, apply only to the MASTER board. These switches are not relevant to other 2348-010 boards connected to the MASTER board via the ribbon cable and can be left in the OFF position.

Master Board Identification SW-1 Switch Settings								
SW-1	Elevator Shaft Number							
	1	2	3	4	5	6	7	8
Switch 1	OFF	ON	OFF	ON	OFF	ON	OFF	ON
Switch 2	OFF	OFF	ON	ON	OFF	OFF	ON	ON
Switch 3	OFF	OFF	OFF	OFF	ON	ON	ON	ON

Table 3

3.2.2 Floor Identification

Each of the 2348-010 elevator control boards connected to the system must be set to identify which floors that the board will control in the shaft that it is in. The floor setting is set by switch SW-2, switches 1 and 2 (Table 4.).

Floor Identification SW-2 Switch Settings				
SW-2	Floors			
	1-16	17-32	33-48	49-64
Switch 1	OFF	ON	OFF	ON
Switch 2	OFF	OFF	ON	ON

Table 4

3.2.3 Floor Control Relay Settings

Each of the 16 floor control relays on the 2348-010 elevator control board can be set to operate as either a normally open (N.O.) or normally closed (N.C.) device. This is accomplished by the shorting pins located next to each of the relays. SW-1 switch 8 also affects these 16 relays and how they operate. If SW-1 switch 8 is in the OFF position, the 16 elevator button relays on the board will not energize when power is applied to the board. If SW-1 switch 8 is in the ON position, the 16 elevator button relays on the board will energize when power is applied to the board.

NOTE: The setting of SW-1 switch 8 does not affect the LOBBY HALL UP CALL relay. Refer to 3.2.4 for more information on the CALL relay.

The normal (and recommended) settings for the 16 floor control relays is N.C. (normally closed). This provides normal elevator button operation should the 2348-010 board(s) lose power or become disabled by any other means. Likewise, the normal (and recommended) setting for SW-1 switch 8 is ON so that when the 2348-010 board powers up, all 16 elevator button relays on the board will energize and thus result in an open output circuit since the relays are set for N.C. operation. **If the relays are set for normally open (N.O.) operation and the 2348 board loses power or becomes disabled by any other means, the floor buttons in the elevator will work.**

3.2.4 Lobby Hall Up Call Relay

The LOBBY HALL UP CALL relay is a special relay on the 2348-010 elevator control board that can be programmed to "call" the elevator to the lobby or ground floor when a visitor is granted access by the access control system. Only the LOBBY HALL CALL relay on the system MASTER board(s) activates when access is granted. The LOBBY HALL CALL relay feature is turned on or off by SW-2 switch 8, and like the other relays on the 2348-010 board it can be set to operate as either a normally open (N.O.) or normally closed (N.C.) device. The normal setting for the LOBBY HALL CALL relay is N.O.

If SW-2 switch 8 is in the ON position, the LOBBY HALL CALL relay WILL NOT activate when access has been granted. If SW-2 switch 8 is in the OFF position, the LOBBY HALL CALL relay WILL activate when access is granted and will cause the elevator car to go to the lobby (or whatever floor the call relay has been wired to) floor. The setting of SW-2 switch 8 also affects the start of the time allowed for the floor control relays to be active. When this switch is in the ON position, the time that the floor control relay(s) activates begins immediately after access has been granted. If the switch is in the OFF position, the time begins only after the ground floor detect input is activated on the 2348-010 board.

Careful thought should be given to this function. If the switch is in the ON position (lobby hall call feature is turned off), the time setting in the software must be set high enough to allow the elevator to reach the first floor from the top floor, and allowance must also be made for the time it takes a visitor to reach the elevator after they have entered the building. For example, if the time in the software was set to 30 seconds, but it takes the elevator 45 seconds to reach the first floor from the top floor, the amount of time that the floor control relay is active will have expired by time the elevator reached the first floor. The visitor will find that the buttons in the elevator are inoperative.

When SW-2 switch 8 is in the OFF position (lobby hall call feature is turned on), the time that the floor control relay(s) are turned on begins when the ground floor detect input on the 2348-010 board is activated. **Note that if lobby hall call is used, a ground floor detect input must be received by the 2348-010 board, otherwise the floor control button(s) will never become active.**

For information on programming the amount of time that the floor control relays are turned on, refer to the [Remote Account Manager User's Manual](#) (P/N 1835-066).

3.3 Switch Settings & Description

SW 1 (TOP SWITCH)			
SWITCH	FUNCTION	SETTING	DESCRIPTION
1 – 2 - 3	Elevator Shaft Identification		Identifies which elevator shaft the MASTER board is controlling. See table 3, page 16 for switch matrix. Refer to section 3.2.1 for detailed information.
4 thru 7	Spare	OFF	Spare switches. Leave in OFF position
8	Relay Activation	OFF	Floor control relays WILL NOT energize when power is applied to the board.
		ON	Floor control relays WILL energize when power is applied to the board.

Switches 1-2-3: These switches identify which elevator shaft the 2348 circuit board is controlling. Refer to the switch matrix (table 3) on page 16 for switch settings to identify elevator shafts 1 – 8.

Switches 4-7: Spare switches. Leave in the OFF position.

Switch 8: This switch sets the floor control relays to either energize or not energize when power is applied to the circuit board. This switch setting is used in conjunction with the N.O. (Normally Open) and N.C. (Normally Closed) relay setting on the circuit board. Refer to section 3.2.3 for more information.

SW 2 (BOTTOM SWITCH)			
SWITCH	FUNCTION	SETTING	DESCRIPTION
1 – 2	Floor Identification		Identifies which floors the elevator board is controlling. See table 4, page 16.
3 thru 7	Spare	OFF	Spare switches. Leave in OFF position
8	Lobby Hall Call Relay	OFF	Lobby Hall Call relay activates when visitor access is granted. Ground floor detect input must be used if this switch is in the OFF position.
		ON	Lobby Hall Call relay not used.

Switches 1-2: These switches identify which floors the elevator board is controlling. Refer to the switch matrix (table 4) on page 16 for switch settings to identify floors controlled.

Switches 3-7: Spare switches. Leave in the OFF position.

Switch 8: This switch should be in the OFF position if the Lobby Hall Up Call relay is used to call the elevator car to the lobby (or ground) level when visitor access is granted. **The ground floor detect input must be used when this switch is in the OFF position.** Floor control relay activation timing starts when the ground floor detect input is activated. If the Lobby Hall Up Call relay is not used, this switch must be in the ON position. Floor control relay activation timing starts when visitor access is granted. Refer to section 3.2.4 for more information.

Section 4 – Wiring Information

Prior to installing wiring to the elevator control board(s), we suggest that you become familiar with the instructions, illustrations, and wiring guidelines in this manual. This will help insure that your installation is performed in an efficient and professional manner.

The wiring of the elevator control board(s) is an extremely important and integral part of the overall access control system. Use proper wire for the weigand lines, power wires, and be sure that the system is properly grounded. Check all local building ordinances and building codes prior to installing this system. Be sure your installation is in compliance with local codes. Wiring of this system will have to be coordinated with the elevator service company. Only qualified elevator service personnel should interface the elevator button relays with the elevator electronic control panel.

4.1 General Information

Use only the supplied 16 VAC, 40 VA transformer (or U.L. listed equivalent) to power the elevator control board. One (1) elevator control cabinet (max 4 boards) can be powered from a single transformer. Do not power any other devices (electric strikes, magnetic locks, etc.) from these power transformers. For wire runs up to 100 feet, use 18 AWG, 600 volt insulated wire. For wire runs up to 200 feet, use 16 AWG, 600 volt insulated wire. Power wires are susceptible to noise and hum pickup; therefore it is preferable that you keep power wire runs as short as possible.

The 2348-010 elevator control board contains a number of static sensitive components that can be damaged or destroyed by static discharges during installation or use. Discharge any static prior to removing any circuit board from the cabinet by touching a proper ground device.

Proper grounding of this system is a requirement. The use of surge suppressers can significantly reduce the chance of component failure because of static charges or surges. To be effective, ground connections should be made with a minimum 12 AWG, 600 volt insulated wire to a ground point within 10 feet of the system. The ground point must be at an electrical panel, a metallic cold water pipe that runs in the earth, or a stainless steel grounding rod driven at least ten (10) feet into the soil. If there are several elevator boards and other components in the access control system in close proximity to each other, you should consider using a single point ground. Check with your building department for specific grounding guidelines as soil conditions and grounding requirements differ depending on your geographical location.

Use low voltage (P/N 1878-010) surge suppressers on low voltage power runs to help protect equipment from damage because of power spikes and surges. Use DoorKing surge suppressers or equivalent.

All wires should be placed in conduits. Proper pre-planning can greatly ease the installation and wiring of this system. Always check with the local building code to determine the type of wire required in your municipality.

4.2 Control Board Terminal Identification

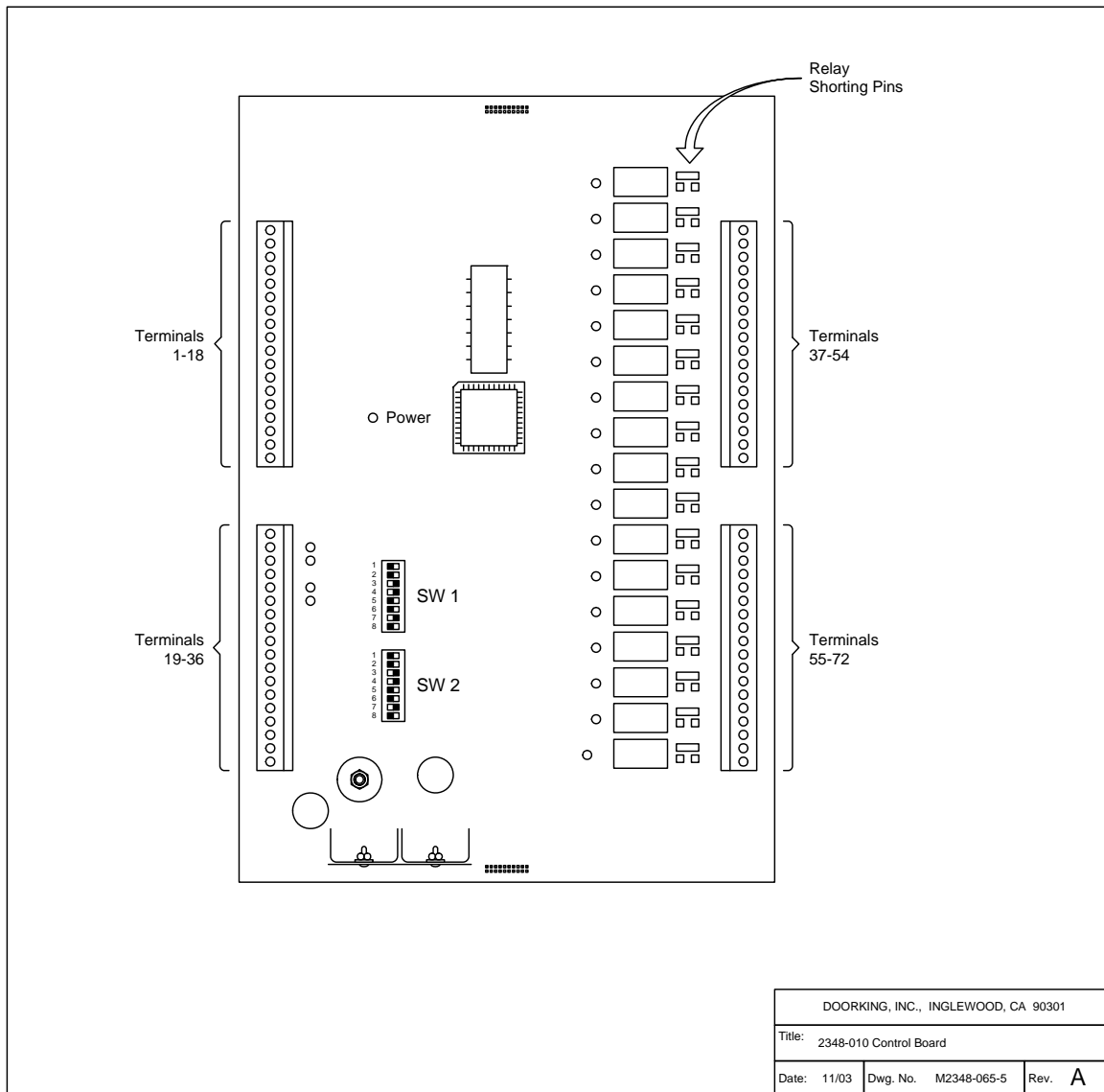

Figure 5

Left Terminals		Right Terminals	
1	Not Used	37	Relay 16
2			
3			
4			
5			
6			
7			
8			
9			
10			
11			
12			
13			
14			
15			
16			
17	Ground Floor Detect Input	38	
18			
		39	Relay 15
		40	
		41	Relay 14
		42	
		43	Relay 13
		44	
		45	Relay 12
		46	
		47	Relay 11
		48	
		49	Relay 10
		50	
		51	Relay 9
		52	
		53	Relay 8
		54	
19	Not Used	55	Relay 7
20	Data 1 – Wiegand Input 1	56	
21	Data 0 – Wiegand Input 1	57	Relay 6
22	Common – Wiegand Input 1	58	
23	Data 1 – Wiegand Input 2	59	Relay 5
24	Data 0 – Wiegand Input 2	60	
25	Common – Wiegand Input 2	61	Relay 4
26	Not Used	62	
27			
28			
29			
30			
31			
32			
33			
34	Earth Ground	63	Relay 3
35	16 VAC Input	64	
36			65
		66	
		67	Relay 1
		68	
		69	Lobby Hall Up Call Relay
		70	
		71	Not Used
		72	

4.3 Power Wiring Block Diagram

The elevator control boards must be supplied with 16 VAC power and be properly grounded. Each elevator cabinet can be powered from a single transformer.

- Use 18 AWG 600 volt insulated wire for power runs up to 100 feet and 16 AWG 600 volt insulated wire for power runs up to 200 feet. Try to keep all power wire runs as short as possible.
- Use a minimum 12 AWG wire for ground.
- Because local building codes vary from city to city, we urge you to check with the local building department to determine the type of wire required for all wiring applications. Be sure to color code all wires.

If multiple transformers are required to power several elevator control cabinets, consider using the DoorKing model 1200 Transformer Box (P/N 1200-080). This ETL listed box provides a lockable enclosure that can house up to four (4) transformers to meet your power requirements.

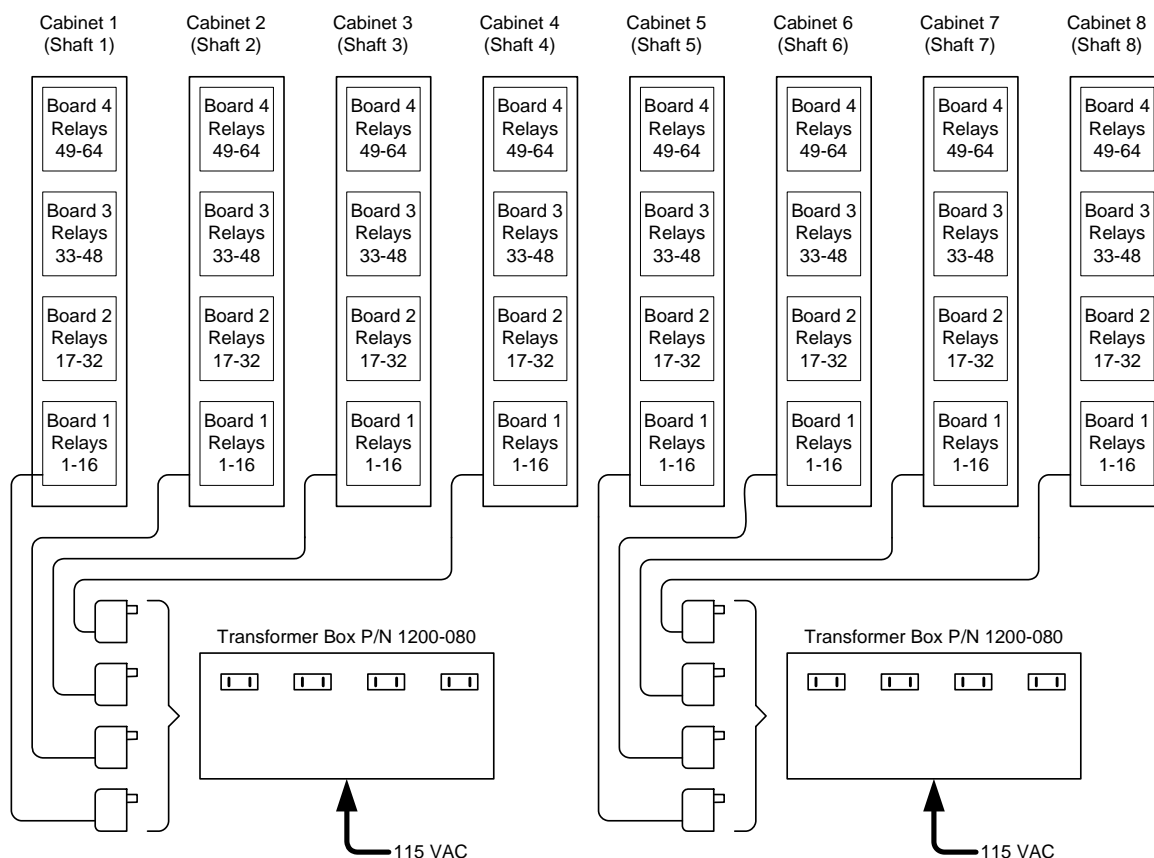

Figure 6

4.4 Control Wiring

Use the figures on the next two pages to assist you with wire connections to the 2348 Elevator Control Board.

4.4.1 Wiegand Wiring

Up to eight (8) MASTER 2348-010 elevator control boards can be connected to a single access control system. Each MASTER board can have an additional three (3) elevator control boards connected to it for control of up to 64 floors (16 floor relays on each board).

There are two wiegand inputs to the 2348-010 elevator control board. Each wiegand input can have two (2) access control systems connected to it. In this manner, a maximum of four (4) access control systems can be connected to the board for elevator control.

- Maximum wiegand wire run is 500 feet.
- Recommended wire type is Belden 9418 or equivalent.
- Float the shield at the elevator board. Do not connect the shield to elevator board common.
- Do not use twisted pair with wiegand output format.

4.4.2 Floor Control Relay Wiring

Interconnecting the floor control relay wiring from the 2348-010 elevator board with the elevator control panel should be performed by a qualified elevator service technician only. We recommend that all functions of the elevator control board be tested prior to wiring the floor control relays to the elevator electronic control panel.

For safety reasons, the preferred method of operation is for the floor control relays to be set for N.C. operation. The diagrams on the next pages assume this method of operation.

- Be sure that the relays on the 2348-010 control board are set for normally closed (N.C.) operation. The shorting bars next to the relays should be on the NC pins for each relay.
- Be sure that SW1, switch 8 is in the ON position (refer to section 3.2.3).
- Route wiring from the 2348-010 cabinet(s) to the elevator control panel (Fig 7, 8). Be sure to color code and mark all wiring!
- The relay contacts on the 2348-010 elevator control board are rated for 1 amp at 125 VAC. Use 18 AWG 600 volt insulated wire (or better) for relay wiring, or use wiring as specified by the elevator service-company or local code.
- Jumper all floor control relay common terminals together to provide a single common wire for floor control.
- A separate floor control relay contact is provided to the elevator control system for each floor.
- Use the charts in the back of this manual to list all connections made and which relays interface with which floor buttons in the elevator car.

4.4.3 Lobby Hall Up Call Relay

The Lobby Hall Up Call Relay (terminals 69-70) is a special relay that activates when access has been granted and "calls" the elevator car to the lobby or ground floor.

- Be sure that the lobby hall call relay is set for Normally Open (N.O.) operation.
- SW-2, switch 8 must be in the OFF position for the LOBBY HALL CALL function to operate. NOTE: If the LOBBY HALL CALL relay function is used (SW-2, switch 8 OFF), then the elevator detect switch must be connected to the 2348-010 control board (see 3.2.4).

4.4.4 Ground Floor Detect Switch

The ground floor detect switch signals the 2348-010 elevator control board that the elevator car has arrived at the lobby or ground floor. This signal is in the form of a switch closure across terminals 17 and 18 and may be available from existing hardware in the elevator electronics panel. Consult with the elevator service technician regarding this switch input.

- Connect a Normally Open (N.O.) ground floor detect switch to terminals 17 and 18 (fig 7).
- Note: Dry contact - no voltage.
- The switch must activate when the elevator car is at the lobby or ground floor.

4.4.5 Resident Elevator Access Device

Each elevator car that is controlled by the access system must have an access device (card reader, keypad, etc.) installed in the elevator car so that the access system knows which floor(s) the resident is to be granted access to.

- Installing the access device in the elevator car should be coordinated with the elevator service company since wiring from the access device inside the elevator car will have to be routed along the elevator electrical umbilical cable to the access controller.
- Refer to the access control system installation manual for additional wiring instructions.
- Route the wiring from the access device to the access control system via the elevator electrical umbilical (fig. 8).
- Connect this wiring as specified in the access control system installation manual. There is no direct connection of the access device to the 2348-010 Elevator Control Board.

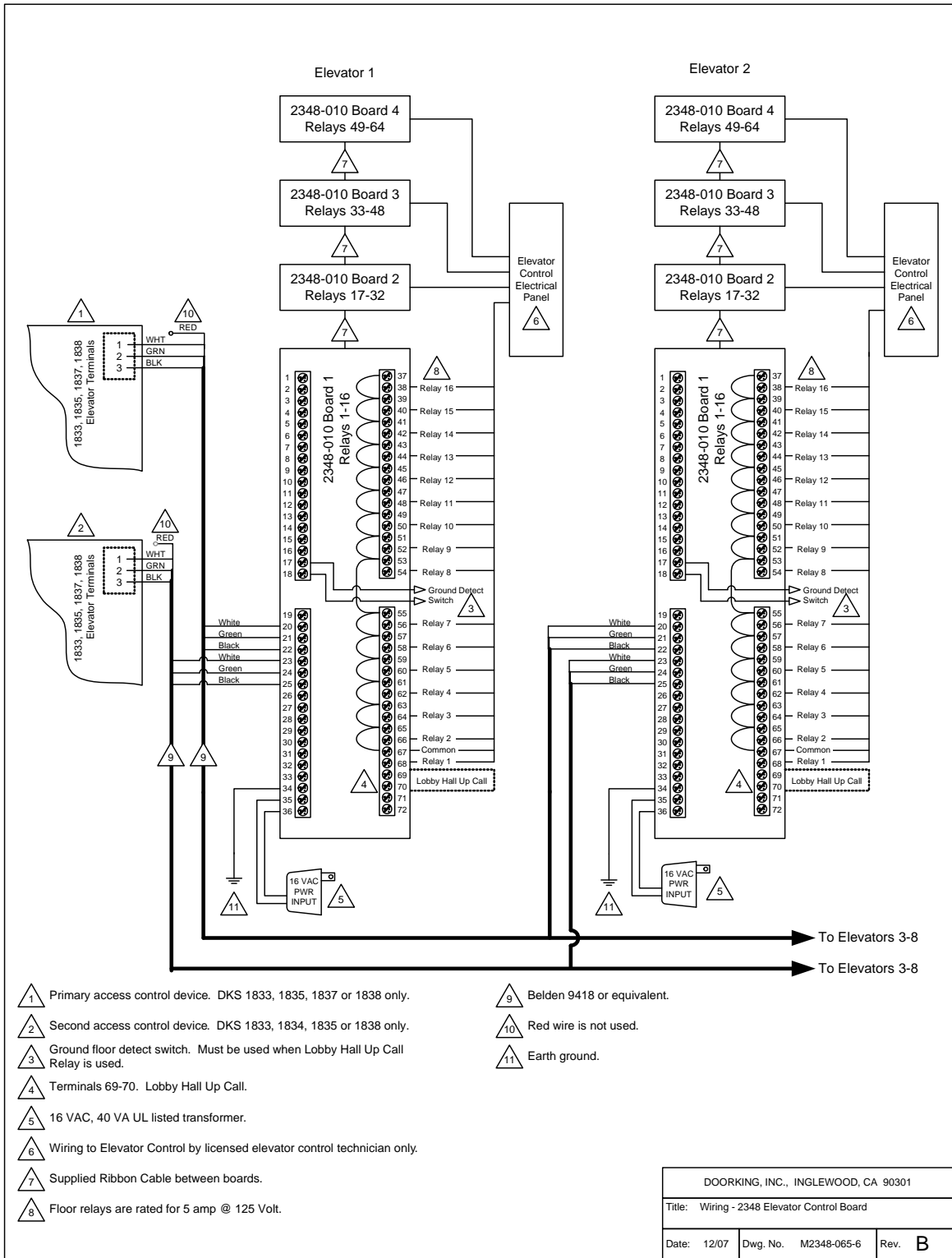
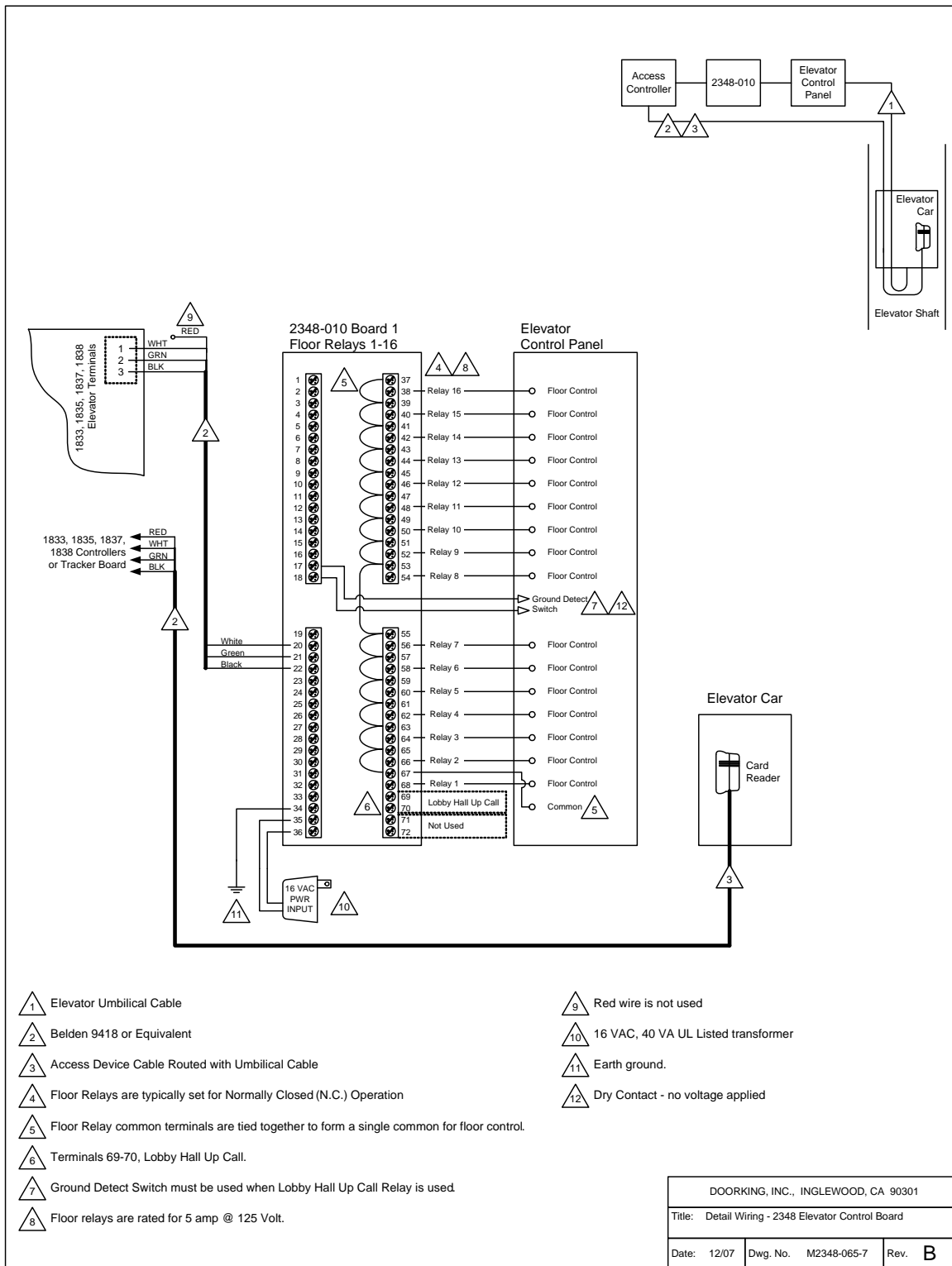

Figure 7



- △1 Elevator Umbilical Cable
- △2 Belden 9418 or Equivalent
- △3 Access Device Cable Routed with Umbilical Cable
- △4 Floor Relays are typically set for Normally Closed (N.C.) Operation
- △5 Floor Relay common terminals are tied together to form a single common for floor control.
- △6 Terminals 69-70, Lobby Hall Up Call.
- △7 Ground Detect Switch must be used when Lobby Hall Up Call Relay is used
- △8 Floor relays are rated for 5 amp @ 125 Volt.
- △9 Red wire is not used
- △10 16 VAC, 40 VA UL Listed transformer
- △11 Earth ground.
- △12 Dry Contact - no voltage applied

DOORKING, INC., INGLEWOOD, CA 90301		
Title: Detail Wiring - 2348 Elevator Control Board		
Date: 12/07	Dwg. No. M2348-065-7	Rev. B

Figure 8

Section 5 - Elevator Control

5.1 Common Oversights

Floor Button Wiring - Remember that the relays for floor control start at the bottom of the board and count UP. Terminals 67 & 68 are for the first or lowest controlled floor. Terminals 65 & 66 are for the second controlled floor; terminals 63 & 64 are for the third controlled floor, etc., etc.

First Floor - Remember that the Lobby Level should not be controlled or connected to the elevator control board. Look at the building and determine which floors, not counting the lobby, will require floor level control. The relay at terminals 67 & 68 may control a parking level, the 2nd floor, etc.

N.O. vs N.C. Relay Setting - Elevator equipment may require either N.C or N.O connections for their floor button controls. Also, remember that this is tied in with the Fail Safe / Fail Secure setting of the system (controlled by SW1, Switch 8).

- **Normal Operation (Fail Safe)** - SW1, Switch 8 is set in ON position. All relay jumpers should be set for N.C. operation. In this mode, all floor control relays and LED's will activate when board is powered up. When a floor level access command is initiated, the relay and LED will deactivate, providing a contact closure, which enables the floor button. Loss of power to the elevator control board will provide a contact closure for all floor control relays. This does not affect the Lobby Hall Up Call relay.
- **Special Applications (Fail Secure)** - SW1, Switch 8 OFF. All relay jumpers should be set for N.O. operation. In this mode, all floor control relays and LED's will be off when the board is powered up. When a floor level access command is initiated, the relay and LED will activate, providing a contact closure, which enables the floor button. Loss of power will disable all floor buttons. This does not affect the Lobby Hall Up Call relay.

Lobby Hall Up Call Function - Remember, to utilize the Lobby Hall Up Call relay, you must be provided with a **Ground Floor Detect** contact from the elevator equipment. If there is not a ground floor detect available, then you cannot utilize this function.

- **SW2, Switch 8 ON** - No Lobby Hall Up Call relay activation. Visitor timing starts when visitor access is granted through the entry system. Ground floor detect is not required.
- **SW2, Switch 8 OFF** - Ground Floor Detect contact must be provided to 2348 board to identify when elevator reaches the lobby (or ground) level. When visitor access is granted through the entry system, the LOBBY HALL UP CALL relay will activate momentarily. Visitor timing will not start until elevator reaches lobby (or ground) level.

Card Reader (System Relay) Identification - This is a software programming and set up function (see software section). However, it also is related to hardware. The card reader number is determined by the wiegand port, and the tracker board jumper settings.

Software Issues - Remember to program the following items within the software:

- **Relay/Elevator** - This identifies which reader is inside which elevator.
- **Security Level** - Security Level 01 does not provide elevator control. In Levels 02 – 30, program time zones, select relay and click on floors.
- **Elevator Ref** - In the Resident Screen, this identifies which elevator will respond when visitor access is granted.

5.2 Software Programming

When setting up the Remote Account Manager Software (refer to manual 1835-066), there are some programming steps that must be made in order for the elevator control functions to operate properly:

- **On 1830 series phones** - In the System Information Screen, make sure the selection is made for "1833/1835/1837/1838".
- **If tracker expansion boards are required** - To support the reader device inside the elevator car, check the tracker box in the System Information screen.
- **Security Level 02 or higher** - You must program security levels for building tenants and residents. **The default security level 01 does not provide any elevator control for building tenants!** For 24-hour access to floors you must program a security level for 24 hr, 7 day access and click on all used floor locations.
- **Select Relay and Floor(s)** - Within the Security Level, you must select the relay (card reader) that is inside the elevator, and any floors that the users will be allowed to access.
- **Relay / Elevator** - You must identify which system reader is inside which elevator car. This is performed in the Relay/Elevator screen.
- **Elevator Reference Number** - In Resident Screen, this tells which elevator will respond a specific tenant when they grant access to a visitor.

The following pages show these various screens and provide some quick reference information on setting up and programming the Remote Account Manager Software for elevator control functions. For further details, please refer to the Remote Account Manager Software manual (1835-066).

System Information: Relay Screen

Relay Screen - In the Relay Screen, you should label which “system relays” refer to the reader devices inside the elevator car(s).

This is for labeling and reference only and does not affect the function or operation of the system.

You MUST program the relay address at the relay/elevator screen.

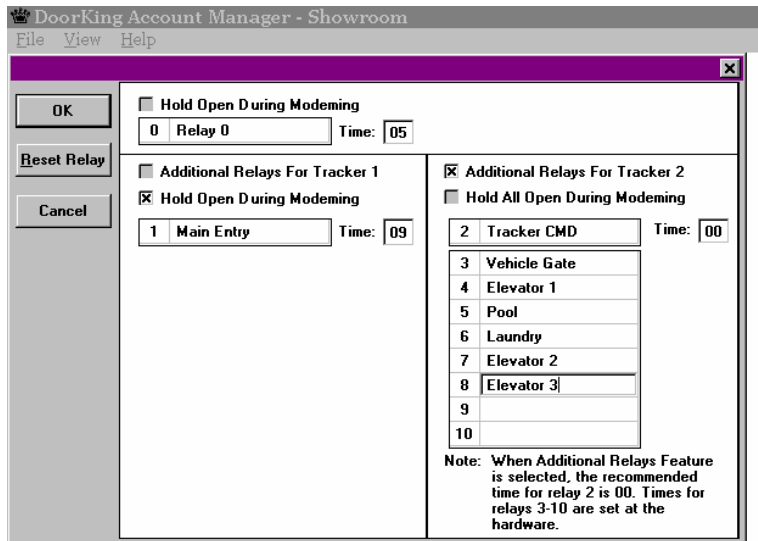

System Information: Security Level – Relay / Elevator

Relay/Elevator screen - This addresses which system relay is inside each elevator car. This tells the system that activation of the card reader at system relay #4 is a person inside elevator #1. The system will then look at the security level programming and sends the appropriate commands up to the elevator control board.

This example shows that:
 Relay #4 is in Elevator #1
 Relay #7 is in Elevator #2
 Relay #8 is in Elevator #3

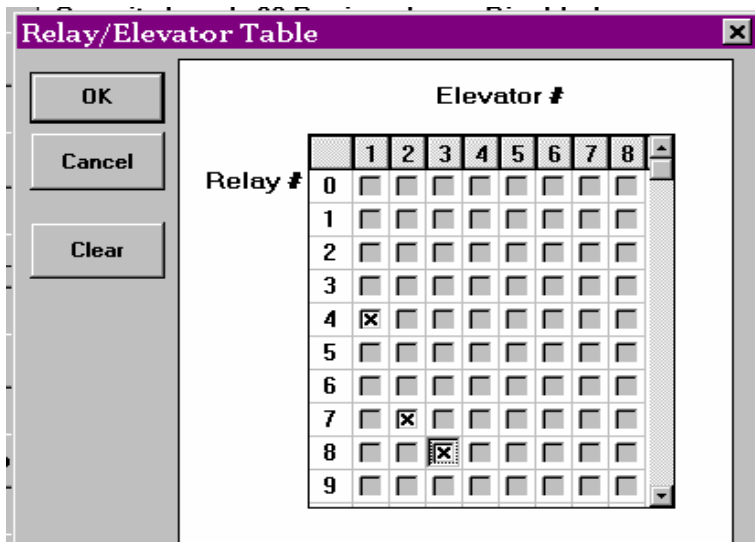

Relay #	1	2	3	4	5	6	7	8
0								
1								
2								
3								
4	☒							
5								
6								
7		☒						
8			☒					
9								

System Information: Security Level

Programming of Floor Button Access for building tenants is done in the Security Level Screen. Each resident is assigned to one of the programmed security levels. Within each security level, you select which floor or floors they will have access to and if any time zone restrictions will apply. **This does not affect visitor elevator control.**

- **Security Level 01 DOES NOT PROVIDE ELEVATOR CONTROL FUNCTIONS.** This security level provides 24/7 access at all reader locations. However, elevator commands will not be sent from the phone system to elevator board.
- **Security Level 02, time zone (TZ) 1.** Programmed for 24 hr, 7 day access.
- **Relays** - To program Elevator Control, select the relays that reference the card readers located inside the elevator cars. In this case, relays 4, 7 & 8.
- **Floors** - To program floor level control, select which floors will be included within this time zone. The example shows that Floors P1, 2, 3 & 4 will be provides with 24hr, 7 day access.

DoorKing Account Manager - Showroom
File View Help

Security Level 02, Time Zone 1 [X]

Security Level: 00 Device always Disabled
Security Level: 01 Device always Enabled
Security Level: Time Zones:

Time:

BEGIN TIME	END TIME	S	M	T	W	T	F	S
12:00 AM	11:59 PM	<input checked="" type="checkbox"/>	<input checked="" type="checkbox"/>	<input checked="" type="checkbox"/>	<input checked="" type="checkbox"/>	<input checked="" type="checkbox"/>	<input checked="" type="checkbox"/>	<input checked="" type="checkbox"/>

Relays:

0	1	2	3	4	5	6	7	8	9	10	11	12	13	14	15	16	17	18
<input type="checkbox"/>	<input checked="" type="checkbox"/>	<input type="checkbox"/>	<input checked="" type="checkbox"/>	<input checked="" type="checkbox"/>	<input type="checkbox"/>	<input type="checkbox"/>	<input checked="" type="checkbox"/>	<input checked="" type="checkbox"/>	<input type="checkbox"/>	<input type="checkbox"/>	<input type="checkbox"/>	<input type="checkbox"/>	<input type="checkbox"/>	<input type="checkbox"/>	<input type="checkbox"/>	<input type="checkbox"/>	<input type="checkbox"/>	<input type="checkbox"/>

* To change the floor name, double-click on it

Floors:

P1	2	3	4	FT	6	7	8	9	10	11	12	13	14	15	16
<input checked="" type="checkbox"/>	<input checked="" type="checkbox"/>	<input checked="" type="checkbox"/>	<input checked="" type="checkbox"/>	<input type="checkbox"/>	<input type="checkbox"/>	<input type="checkbox"/>	<input type="checkbox"/>	<input type="checkbox"/>	<input type="checkbox"/>	<input type="checkbox"/>	<input type="checkbox"/>	<input type="checkbox"/>	<input type="checkbox"/>	<input type="checkbox"/>	<input type="checkbox"/>
17	18	19	20	21	22	23	24	25	26	27	28	29	30	31	32
<input type="checkbox"/>	<input type="checkbox"/>	<input type="checkbox"/>	<input type="checkbox"/>	<input type="checkbox"/>	<input type="checkbox"/>	<input type="checkbox"/>	<input type="checkbox"/>	<input type="checkbox"/>	<input type="checkbox"/>	<input type="checkbox"/>	<input type="checkbox"/>	<input type="checkbox"/>	<input type="checkbox"/>	<input type="checkbox"/>	<input type="checkbox"/>
33	34	35	36	37	38	39	40	41	42	43	44	45	46	47	48
<input type="checkbox"/>	<input type="checkbox"/>	<input type="checkbox"/>	<input type="checkbox"/>	<input type="checkbox"/>	<input type="checkbox"/>	<input type="checkbox"/>	<input type="checkbox"/>	<input type="checkbox"/>	<input type="checkbox"/>	<input type="checkbox"/>	<input type="checkbox"/>	<input type="checkbox"/>	<input type="checkbox"/>	<input type="checkbox"/>	<input type="checkbox"/>
49	50	51	52	53	54	55	56	57	58	59	60	61	62	63	64
<input type="checkbox"/>	<input type="checkbox"/>	<input type="checkbox"/>	<input type="checkbox"/>	<input type="checkbox"/>	<input type="checkbox"/>	<input type="checkbox"/>	<input type="checkbox"/>	<input type="checkbox"/>	<input type="checkbox"/>	<input type="checkbox"/>	<input type="checkbox"/>	<input type="checkbox"/>	<input type="checkbox"/>	<input type="checkbox"/>	<input type="checkbox"/>

OK
Cancel
View Active SLs
Relays
Relay/Elevator
Clear Time Zone

System Information: Security Level

Programming of Floor Button Activation for building tenants is done in the Security Level Screen. Each resident is assigned to one of the programmed Security Levels. Within each security level, you select which floor or floors they will have access to and if any time zone restrictions will apply. **This does not affect visitor elevator control**

- **Security Level 02, time zone 2** - Programmed for access 7 AM – 9 PM, M-F.
- **Relays** - To program elevator control, select the relays that reference the card readers located inside the elevator cars. In this case, relays 4, 7 & 8.
- **Floors** - To program floor level control, select which floors will be included within this time zone. The example shows that the Fitness Center on Floor “FT” will have access from 7AM – 9PM, Monday – Friday.

DoorKing Account Manager - Showroom
File View Help

Security Level 02, Time Zone 2 [X]

Security Level: 00 Device always Disabled
Security Level: 01 Device always Enabled
Security Level: Time Zones:

Time:

BEGIN TIME	END TIME	S	M	T	W	T	F	S
07:00 AM	09:00 PM	<input type="checkbox"/>	<input checked="" type="checkbox"/>	<input checked="" type="checkbox"/>	<input checked="" type="checkbox"/>	<input checked="" type="checkbox"/>	<input checked="" type="checkbox"/>	<input type="checkbox"/>

Relays:

0	1	2	3	4	5	6	7	8	9	10	11	12	13	14	15	16	17	18
<input type="checkbox"/>	<input type="checkbox"/>	<input type="checkbox"/>	<input type="checkbox"/>	<input checked="" type="checkbox"/>	<input checked="" type="checkbox"/>	<input checked="" type="checkbox"/>	<input checked="" type="checkbox"/>	<input checked="" type="checkbox"/>	<input type="checkbox"/>	<input type="checkbox"/>	<input type="checkbox"/>	<input type="checkbox"/>	<input type="checkbox"/>	<input type="checkbox"/>	<input type="checkbox"/>	<input type="checkbox"/>	<input type="checkbox"/>	<input type="checkbox"/>

* To change the floor name, double-click on it

Floors:

P1	2	3	4	FT	6	7	8	9	10	11	12	13	14	15	16
<input type="checkbox"/>	<input type="checkbox"/>	<input type="checkbox"/>	<input type="checkbox"/>	<input checked="" type="checkbox"/>	<input type="checkbox"/>	<input type="checkbox"/>	<input type="checkbox"/>	<input type="checkbox"/>	<input type="checkbox"/>	<input type="checkbox"/>	<input type="checkbox"/>	<input type="checkbox"/>	<input type="checkbox"/>	<input type="checkbox"/>	<input type="checkbox"/>
17	18	19	20	21	22	23	24	25	26	27	28	29	30	31	32
<input type="checkbox"/>	<input type="checkbox"/>	<input type="checkbox"/>	<input type="checkbox"/>	<input type="checkbox"/>	<input type="checkbox"/>	<input type="checkbox"/>	<input type="checkbox"/>	<input type="checkbox"/>	<input type="checkbox"/>	<input type="checkbox"/>	<input type="checkbox"/>	<input type="checkbox"/>	<input type="checkbox"/>	<input type="checkbox"/>	<input type="checkbox"/>
33	34	35	36	37	38	39	40	41	42	43	44	45	46	47	48
<input type="checkbox"/>	<input type="checkbox"/>	<input type="checkbox"/>	<input type="checkbox"/>	<input type="checkbox"/>	<input type="checkbox"/>	<input type="checkbox"/>	<input type="checkbox"/>	<input type="checkbox"/>	<input type="checkbox"/>	<input type="checkbox"/>	<input type="checkbox"/>	<input type="checkbox"/>	<input type="checkbox"/>	<input type="checkbox"/>	<input type="checkbox"/>
49	50	51	52	53	54	55	56	57	58	59	60	61	62	63	64
<input type="checkbox"/>	<input type="checkbox"/>	<input type="checkbox"/>	<input type="checkbox"/>	<input type="checkbox"/>	<input type="checkbox"/>	<input type="checkbox"/>	<input type="checkbox"/>	<input type="checkbox"/>	<input type="checkbox"/>	<input type="checkbox"/>	<input type="checkbox"/>	<input type="checkbox"/>	<input type="checkbox"/>	<input type="checkbox"/>	<input type="checkbox"/>

Buttons: OK, Cancel, View Active SLs, Relays, Relay/Elevator, Clear Time Zone

Resident Screen

The Resident Screen includes various programming information that will affect the elevator control, both for building tenants (residents) and for visitor access.

- **SL (Security Level)** - This assigns one of the programmed Security Levels to the resident. The security level will provide control of Floor Level access for the resident. Remember, **Security Level 01 will not provide elevator control.**
- **FL (Residents Floor)** - This identifies which floor the resident lives on. Visitors granted access by the resident will only have access to this specific floor.
- **ER (Elevator Reference #)** - This number pertains to the Elevator Reference Screen (see below). It controls which elevator is called down when visitor access is granted, and how long the resident's floor button will be active for the visitor.

DoorKing Account Manager - Showroom											
File View Help											
Add	C				008						
Edit	Resident Name	H	AAC	Phone	Dir	Ent	SL	T	Device#	FL	ER
Add Device	A QUIUAN	<input type="checkbox"/>		769-1118	113	8844	02		00020	6	1
Add Vendor	AARONS	<input type="checkbox"/>		776-6543	003		03				1
Delete	ALBERTO ROJAS	<input type="checkbox"/>		762-4589	164	6262	02		00067	3	3
Assign		<input type="checkbox"/>						A	42000		
Sort		<input type="checkbox"/>						A	42721		
Search	ARROYO R	<input type="checkbox"/>		769-1392	140	2931	02		00039	4	3
Statistics		<input type="checkbox"/>							00061		
Sec. Level	BARNES C	<input type="checkbox"/>		762-2082	107	2802	02		00008	2	3
Elevator Ref	BARRON	<input type="checkbox"/>		762-1791	913	1971	02		00068	2	1
Accounts	BEASLEY E	<input type="checkbox"/>			655		02	A	42672	4	2
	BILBO	<input type="checkbox"/>		696-2630	144	0362	02		00042	7	3
	BOND JAMES	<input type="checkbox"/>			007		03	A	42671	3	1
	BROOKS	<input type="checkbox"/>		762-4188	129	8814	02		00028	4	1
	CARTER	<input type="checkbox"/>		696-9992	148	2999	02		00046	6	1

Resident Screen: Elevator Reference Table

The Elevator Reference Table controls two basic functions; which elevator or Elevators will be called down to the lobby (or ground) level when a visitor is granted access, and how long the resident floor control relay will be enabled.

- **Elevator Reference Number** - Each resident of building tenant is assigned an Elevator Reference Number. This tells the system which elevator will be called when visitor access is granted. **Note: If a ground floor detect is not provided from the elevator control panel, the Lobby Hall Up Call feature cannot be used!**
- The elevator reference number also identifies which elevators will respond to the floor button control for visitor access and how long the residents floor button will be enabled. **If ground floor detect is not provided, floor button timing starts when resident dials "9" on phone.**
- The example below shows that:
 - Elevator Reference 1: Calls elevator 1 to the lobby. When the elevator reaches the lobby, the resident floor button will be active for 1 minute.
 - Elevator Reference 2: Calls elevator 1 to lobby, floor button is enabled for 30 seconds.
 - Elevator Reference 3: Calls elevators 1, 2 & 3 to lobby. Floor buttons enabled in each elevator for 3:30 seconds.

The screenshot shows the 'DoorKing Account Manager - Showroom' interface. A central window titled 'Elevator Reference Table' is open, displaying a table for configuring elevator references. The table has columns for 'Elevator Number' (ER) and 'Time (min:sec)'. The rows represent different elevator reference numbers (1-8). Checkmarks in the 'Elevator Number' columns indicate which elevators are called for each reference. The 'Time' column shows the duration the floor button is enabled.

ER	1	2	3	4	5	6	7	8	Time (min:sec)
1	<input checked="" type="checkbox"/>	<input type="checkbox"/>	<input type="checkbox"/>	<input type="checkbox"/>	<input type="checkbox"/>	<input type="checkbox"/>	<input type="checkbox"/>	<input type="checkbox"/>	1:00
2	<input checked="" type="checkbox"/>	<input type="checkbox"/>	<input type="checkbox"/>	<input type="checkbox"/>	<input type="checkbox"/>	<input type="checkbox"/>	<input type="checkbox"/>	<input type="checkbox"/>	0:30
3	<input checked="" type="checkbox"/>	<input checked="" type="checkbox"/>	<input checked="" type="checkbox"/>	<input type="checkbox"/>	<input type="checkbox"/>	<input type="checkbox"/>	<input type="checkbox"/>	<input type="checkbox"/>	3:30
4	<input type="checkbox"/>	<input type="checkbox"/>	<input type="checkbox"/>	<input type="checkbox"/>	<input type="checkbox"/>	<input type="checkbox"/>	<input type="checkbox"/>	<input type="checkbox"/>	1:00
5	<input type="checkbox"/>	<input type="checkbox"/>	<input type="checkbox"/>	<input type="checkbox"/>	<input type="checkbox"/>	<input type="checkbox"/>	<input type="checkbox"/>	<input type="checkbox"/>	1:00
6	<input type="checkbox"/>	<input type="checkbox"/>	<input type="checkbox"/>	<input type="checkbox"/>	<input type="checkbox"/>	<input type="checkbox"/>	<input type="checkbox"/>	<input type="checkbox"/>	1:00
7	<input type="checkbox"/>	<input type="checkbox"/>	<input type="checkbox"/>	<input type="checkbox"/>	<input type="checkbox"/>	<input type="checkbox"/>	<input type="checkbox"/>	<input type="checkbox"/>	1:00
8	<input type="checkbox"/>	<input type="checkbox"/>	<input type="checkbox"/>	<input type="checkbox"/>	<input type="checkbox"/>	<input type="checkbox"/>	<input type="checkbox"/>	<input type="checkbox"/>	1:00

The background window shows a list of accounts with columns for 'Elevator Ref', 'Accounts', and 'ER'. The 'ER' column contains values like 6, 1, 1, 3, 3, 4, 3, 2, 3, 2, 1, 4, 2, 7, 3, 1, 1, 4, 1, 6, 1.

Section 6 – Trouble Shooting

Before beginning any trouble shooting, review Section 5 in this manual and check all wiring and look for any loose connections. Double check your wiring! Be sure that you have a good VOM (Volt-Ohm-Meter) to assist you when checking voltages and continuity. The following manuals may be helpful when trouble shooting the access control system. These manuals are available (PDF format) on the DKS Tech Support web site at www.dkaccess.com.

- P/N 1835-065 Installation manual for the 1833, 1835, 1837 Systems.
- P/N 1838-065 Installation manual for the 1838 Access Controller.
- P/N 2351-065 Installation manual for Tracker expansion boards.
- P/N 1835-066 Remote Account Manager User Manual.

6.1 General Trouble Shooting

- Be sure that the access control system (1833, 1835, 1837 or 1838) is operating properly BEFORE making any connections to the 2348 elevator control board.
- Check for communication between the access control system and the elevator control board using the tests on the following pages.
- If a card reader has been installed in the elevator car, be sure that this card reader is communicating with the access control system.
- Be sure that all necessary programming for elevator control has been set-up in the software and has been down loaded to the access control system.
- Be sure that the POWER LED on each 2348 elevator control board connected in the system is ON when power is applied. If POWER LED is not ON, check for 16 VAC power at terminals 35 and 36 on the MASTER board. The remaining three (3) boards controlling the elevator car in the shaft are powered from the MASTER elevator control board.
- Be sure that all ribbon cables connecting the boards together are plugged in properly.
- Check the visitor control function by calling a resident from the 1833, 1835 or 1837. Have a second person check the elevator control board to be sure that the proper relay activates (relay LED turns ON) when the resident grants access.
- Check the resident control function by activating the card reader in the elevator car with a valid access card. Have a second person check the elevator control board to be sure that the proper floor relay(s) activate (relay LED turns ON) when the system grants access.
- Check the LED next to the wiegand input(s) at terminals 20-22 (wiegand 1 input) and terminals 23-25 (wiegand 2 input). The LED will blink when the access control system(s) (1833, 1835, 1837 or 1838) is sending wiegand data to the elevator control board. If the LED is blinking, wiegand data is being received. If the LED is not blinking, check the wiring to be sure that the Data1, Data 0, and common wires are on the correct terminals.
- Check the DIP switches on the elevator control board. Be sure that the shaft and board numbers are set correctly
- Check SW-2 switch 8 to determine when the elevator control board will activate its programmed floor button relay after a visitor is granted access. If SW-2 switch 8 is OFF, the floor button relay will not activate until the elevator detect switch (a contact closure on terminals 17 and 18) is activated.
- Check that the relay shorting pins are set for proper operation - either normally open (N.O.) or normally closed (N.C.).
- The LOBBY HALL CALL relay shorting pin should be set for normally open (N.O.) operation.

6.2 Programming Trouble Shooting Aids

These trouble shooting steps will involve programming commands into the access control system (1833, 1835, 1837 or 1838). These programming steps will cause the access system to wiegand shaft and floor data to the 2348-010 elevator control board(s) so that it can be determined that the corresponding relay(s) on the elevator control board(s) are operating. Refer to the 1833, 1835, 1837 or 1838 User's Manual for additional information on trouble shooting the access control system. NOTE: Programming functions are entered at the Access Control System (1833, 1835, 1837 or 1838) keypad.

6.2.1 Automatic Test #1

This test will result in the access system sending a series of wiegand commands to the elevator control board at two second intervals. The result is that the CALL relay on the MASTER board (the board with the wiegand wires attached to it) will activate (LED On) momentarily, then ALL the odd numbered relays (1, 3, 5 ... 15) on the master board will activate (LED's On) momentarily, and then ALL the even numbered relays (2, 4, 6 ... 16) on the master board will activate (LED's On) momentarily. This process will repeat itself for the other 2348-010 boards attached to the MASTER board via the ribbon cables with the exception of the CALL relay. The CALL relay will only operate on the MASTER board.

The entire sequence of the relays operating will repeat 10 times and then automatically quit, and will take about four (4) minutes. The purpose of this test is to confirm that communication exists between the access control system board and the elevator control board, and that each of the relays on the elevator control board will activate when a command is sent to it. This test must be repeated for each elevator shaft if there is more than one shaft in the system.

4. Press * **7 6** and then enter the four digit master code _ _ _ _ (beep). The display on the 1835 and 1837 systems will read: WHICH ELEVATOR?
5. Enter the elevator shaft number (1, 2, 3, 4, 5, 6, 7 or 8) _ then press * (beep). The display on the 1835 and 1837 systems will read: ELEVATOR TEST 1. A series of commands as described above will begin. This test is automatic and may take up to 4 minutes to complete.
6. Repeat step 2 to run this test for the other elevator shafts.
7. Press **0 #** together to end this programming sequence (beeeeeep).

6.2.2 Manual Test #2

This programming sequence allows you to test each floor button relay individually.

1. Press * **7 7** and then enter the four digit master code _ _ _ _ (beep). The display on the 1835 and 1837 systems will read: WHICH ELEVATOR?
2. Enter the elevator shaft number (1, 2, 3, 4, 5, 6, 7, or 8) _ then press * (beep). The display on the 1835 and 1837 systems will read: FLOOR?
3. Enter the two digit floor number (02, 03, etc.) _ _ then press * (beep). The relay that represents the information that you entered will activate (LED On).
4. Repeat steps 2 and 3 to check other relays.
5. Press **0 #** together to end this programming sequence (beeeeeep).

6.3 Appendix

We strongly recommend that all wiring connections made from the 2348-010 Elevator Control board to the Elevator Control Panel be marked and labeled. The charts on the following pages should be completed for written documentation of the wiring interface. An example is shown below.

Be sure that all wires are labeled with a wire number or are color coded. Wire numbers should be used in large systems because of the number of wires that are required. The wire ID numbers listed in the Example below were created using the guidelines in Table 5.

1 st Number	2 nd Number	3 rd Number	4 th Number
The shaft number that the wire pertains to.	The board number that the wire pertains to.	Terminal number that the wire connects to.	The floor number that the wire controls.
1	1	37	17

Table 5

Shaft 1 – Board 1 (Master)				Shaft 1 – Board 2			
Relay No.	Board Terminals	Floor No.	Wire ID	Relay No.	Board Terminals	Floor No.	Wire ID
16	37	17	1-1-37-17	16	37	33	1-2-37-33
	38		1-1-38-17		38		1-2-38-33
15	39	16	1-1-39-16	15	39	32	1-2-39-32
	40		1-1-40-16		40		1-2-40-32
14	41	15	1-1-41-15	14	41	31	1-2-41-31
	42		1-1-42-15		42		1-2-42-31
13	43	14	1-1-43-14	13	43	30	1-2-43-30
	44		1-1-44-14		44		1-2-44-30
12	45	12	1-1-45-12	12	45	29	1-2-45-29
	46		1-1-46-12		46		1-2-46-29

Example

Shaft 1 – Board 1 (Master)				Shaft 1- Board 2			
Relay No.	Board Terminals	Floor No.	Wire ID	Relay No.	Board Terminals	Floor No.	Wire ID
16	37			16	37		
	38				38		
15	39			15	39		
	40				40		
14	41			14	41		
	42				42		
3	43			13	43		
	44				44		
12	45			12	45		
	46				46		
11	47			11	47		
	48				48		
10	49			10	49		
	50				50		
9	51			9	51		
	52				52		
8	53			8	53		
	54				54		
7	55			7	55		
	56				56		
6	57			6	57		
	58				58		
5	59			5	59		
	60				60		
4	61			4	61		
	62				62		
3	63			3	63		
	64				64		
2	65			2	65		
	66				66		
1	67			1	67		
	68				68		
LOBBY CALL	69			LOBBY CALL	69		
	70				70		

Shaft 1 – Board 3				Shaft 1- Board 4			
Relay No.	Board Terminals	Floor No.	Wire ID	Relay No.	Board Terminals	Floor No.	Wire ID
16	37			16	37		
	38				38		
15	39			15	39		
	40				40		
14	41			14	41		
	42				42		
3	43			13	43		
	44				44		
12	45			12	45		
	46				46		
11	47			11	47		
	48				48		
10	49			10	49		
	50				50		
9	51			9	51		
	52				52		
8	53			8	53		
	54				54		
7	55			7	55		
	56				56		
6	57			6	57		
	58				58		
5	59			5	59		
	60				60		
4	61			4	61		
	62				62		
3	63			3	63		
	64				64		
2	65			2	65		
	66				66		
1	67			1	67		
	68				68		
LOBBY CALL	69			LOBBY CALL	69		
	70				70		

Shaft 2 – Board 1 (Master)				Shaft 2- Board 2			
Relay No.	Board Terminals	Floor No.	Wire ID	Relay No.	Board Terminals	Floor No.	Wire ID
16	37			16	37		
	38				38		
15	39			15	39		
	40				40		
14	41			14	41		
	42				42		
3	43			13	43		
	44				44		
12	45			12	45		
	46				46		
11	47			11	47		
	48				48		
10	49			10	49		
	50				50		
9	51			9	51		
	52				52		
8	53			8	53		
	54				54		
7	55			7	55		
	56				56		
6	57			6	57		
	58				58		
5	59			5	59		
	60				60		
4	61			4	61		
	62				62		
3	63			3	63		
	64				64		
2	65			2	65		
	66				66		
1	67			1	67		
	68				68		
LOBBY CALL	69			LOBBY CALL	69		
	70				70		

Shaft 2 – Board 3				Shaft 2- Board 4			
Relay No.	Board Terminals	Floor No.	Wire ID	Relay No.	Board Terminals	Floor No.	Wire ID
16	37			16	37		
	38				38		
15	39			15	39		
	40				40		
14	41			14	41		
	42				42		
3	43			13	43		
	44				44		
12	45			12	45		
	46				46		
11	47			11	47		
	48				48		
10	49			10	49		
	50				50		
9	51			9	51		
	52				52		
8	53			8	53		
	54				54		
7	55			7	55		
	56				56		
6	57			6	57		
	58				58		
5	59			5	59		
	60				60		
4	61			4	61		
	62				62		
3	63			3	63		
	64				64		
2	65			2	65		
	66				66		
1	67			1	67		
	68				68		
LOBBY CALL	69			LOBBY CALL	69		
	70				70		

Shaft 3 – Board 1 (Master)				Shaft 3- Board 2			
Relay No.	Board Terminals	Floor No.	Wire ID	Relay No.	Board Terminals	Floor No.	Wire ID
16	37			16	37		
	38				38		
15	39			15	39		
	40				40		
14	41			14	41		
	42				42		
3	43			13	43		
	44				44		
12	45			12	45		
	46				46		
11	47			11	47		
	48				48		
10	49			10	49		
	50				50		
9	51			9	51		
	52				52		
8	53			8	53		
	54				54		
7	55			7	55		
	56				56		
6	57			6	57		
	58				58		
5	59			5	59		
	60				60		
4	61			4	61		
	62				62		
3	63			3	63		
	64				64		
2	65			2	65		
	66				66		
1	67			1	67		
	68				68		
LOBBY CALL	69			LOBBY CALL	69		
	70				70		

Shaft 3 – Board 3				Shaft 3- Board 4			
Relay No.	Board Terminals	Floor No.	Wire ID	Relay No.	Board Terminals	Floor No.	Wire ID
16	37			16	37		
	38				38		
15	39			15	39		
	40				40		
14	41			14	41		
	42				42		
3	43			13	43		
	44				44		
12	45			12	45		
	46				46		
11	47			11	47		
	48				48		
10	49			10	49		
	50				50		
9	51			9	51		
	52				52		
8	53			8	53		
	54				54		
7	55			7	55		
	56				56		
6	57			6	57		
	58				58		
5	59			5	59		
	60				60		
4	61			4	61		
	62				62		
3	63			3	63		
	64				64		
2	65			2	65		
	66				66		
1	67			1	67		
	68				68		
LOBBY CALL	69			LOBBY CALL	69		
	70				70		

Shaft 4 – Board 1 (Master)				Shaft 4- Board 2			
Relay No.	Board Terminals	Floor No.	Wire ID	Relay No.	Board Terminals	Floor No.	Wire ID
16	37			16	37		
	38				38		
15	39			15	39		
	40				40		
14	41			14	41		
	42				42		
3	43			13	43		
	44				44		
12	45			12	45		
	46				46		
11	47			11	47		
	48				48		
10	49			10	49		
	50				50		
9	51			9	51		
	52				52		
8	53			8	53		
	54				54		
7	55			7	55		
	56				56		
6	57			6	57		
	58				58		
5	59			5	59		
	60				60		
4	61			4	61		
	62				62		
3	63			3	63		
	64				64		
2	65			2	65		
	66				66		
1	67			1	67		
	68				68		
LOBBY CALL	69			LOBBY CALL	69		
	70				70		

Shaft 4 – Board 3				Shaft 4- Board 4			
Relay No.	Board Terminals	Floor No.	Wire ID	Relay No.	Board Terminals	Floor No.	Wire ID
16	37			16	37		
	38				38		
15	39			15	39		
	40				40		
14	41			14	41		
	42				42		
3	43			13	43		
	44				44		
12	45			12	45		
	46				46		
11	47			11	47		
	48				48		
10	49			10	49		
	50				50		
9	51			9	51		
	52				52		
8	53			8	53		
	54				54		
7	55			7	55		
	56				56		
6	57			6	57		
	58				58		
5	59			5	59		
	60				60		
4	61			4	61		
	62				62		
3	63			3	63		
	64				64		
2	65			2	65		
	66				66		
1	67			1	67		
	68				68		
LOBBY CALL	69			LOBBY CALL	69		
	70				70		

Shaft 5 – Board 1 (Master)				Shaft 5- Board 2			
Relay No.	Board Terminals	Floor No.	Wire ID	Relay No.	Board Terminals	Floor No.	Wire ID
16	37			16	37		
	38				38		
15	39			15	39		
	40				40		
14	41			14	41		
	42				42		
3	43			13	43		
	44				44		
12	45			12	45		
	46				46		
11	47			11	47		
	48				48		
10	49			10	49		
	50				50		
9	51			9	51		
	52				52		
8	53			8	53		
	54				54		
7	55			7	55		
	56				56		
6	57			6	57		
	58				58		
5	59			5	59		
	60				60		
4	61			4	61		
	62				62		
3	63			3	63		
	64				64		
2	65			2	65		
	66				66		
1	67			1	67		
	68				68		
LOBBY CALL	69			LOBBY CALL	69		
	70				70		

Shaft 5 – Board 3				Shaft 5- Board 4			
Relay No.	Board Terminals	Floor No.	Wire ID	Relay No.	Board Terminals	Floor No.	Wire ID
16	37			16	37		
	38				38		
15	39			15	39		
	40				40		
14	41			14	41		
	42				42		
3	43			13	43		
	44				44		
12	45			12	45		
	46				46		
11	47			11	47		
	48				48		
10	49			10	49		
	50				50		
9	51			9	51		
	52				52		
8	53			8	53		
	54				54		
7	55			7	55		
	56				56		
6	57			6	57		
	58				58		
5	59			5	59		
	60				60		
4	61			4	61		
	62				62		
3	63			3	63		
	64				64		
2	65			2	65		
	66				66		
1	67			1	67		
	68				68		
LOBBY CALL	69			LOBBY CALL	69		
	70				70		

Shaft 6 – Board 1 (Master)				Shaft 6- Board 2			
Relay No.	Board Terminals	Floor No.	Wire ID	Relay No.	Board Terminals	Floor No.	Wire ID
16	37			16	37		
	38				38		
15	39			15	39		
	40				40		
14	41			14	41		
	42				42		
3	43			13	43		
	44				44		
12	45			12	45		
	46				46		
11	47			11	47		
	48				48		
10	49			10	49		
	50				50		
9	51			9	51		
	52				52		
8	53			8	53		
	54				54		
7	55			7	55		
	56				56		
6	57			6	57		
	58				58		
5	59			5	59		
	60				60		
4	61			4	61		
	62				62		
3	63			3	63		
	64				64		
2	65			2	65		
	66				66		
1	67			1	67		
	68				68		
LOBBY CALL	69			LOBBY CALL	69		
	70				70		

Shaft 6 – Board 3				Shaft 6- Board 4			
Relay No.	Board Terminals	Floor No.	Wire ID	Relay No.	Board Terminals	Floor No.	Wire ID
16	37			16	37		
	38				38		
15	39			15	39		
	40				40		
14	41			14	41		
	42				42		
3	43			13	43		
	44				44		
12	45			12	45		
	46				46		
11	47			11	47		
	48				48		
10	49			10	49		
	50				50		
9	51			9	51		
	52				52		
8	53			8	53		
	54				54		
7	55			7	55		
	56				56		
6	57			6	57		
	58				58		
5	59			5	59		
	60				60		
4	61			4	61		
	62				62		
3	63			3	63		
	64				64		
2	65			2	65		
	66				66		
1	67			1	67		
	68				68		
LOBBY CALL	69			LOBBY CALL	69		
	70				70		

Shaft 7 – Board 1 (Master)				Shaft 7- Board 2			
Relay No.	Board Terminals	Floor No.	Wire ID	Relay No.	Board Terminals	Floor No.	Wire ID
16	37			16	37		
	38				38		
15	39			15	39		
	40				40		
14	41			14	41		
	42				42		
3	43			13	43		
	44				44		
12	45			12	45		
	46				46		
11	47			11	47		
	48				48		
10	49			10	49		
	50				50		
9	51			9	51		
	52				52		
8	53			8	53		
	54				54		
7	55			7	55		
	56				56		
6	57			6	57		
	58				58		
5	59			5	59		
	60				60		
4	61			4	61		
	62				62		
3	63			3	63		
	64				64		
2	65			2	65		
	66				66		
1	67			1	67		
	68				68		
LOBBY CALL	69			LOBBY CALL	69		
	70				70		

Shaft 7 – Board 3				Shaft 7- Board 4			
Relay No.	Board Terminals	Floor No.	Wire ID	Relay No.	Board Terminals	Floor No.	Wire ID
16	37			16	37		
	38				38		
15	39			15	39		
	40				40		
14	41			14	41		
	42				42		
3	43			13	43		
	44				44		
12	45			12	45		
	46				46		
11	47			11	47		
	48				48		
10	49			10	49		
	50				50		
9	51			9	51		
	52				52		
8	53			8	53		
	54				54		
7	55			7	55		
	56				56		
6	57			6	57		
	58				58		
5	59			5	59		
	60				60		
4	61			4	61		
	62				62		
3	63			3	63		
	64				64		
2	65			2	65		
	66				66		
1	67			1	67		
	68				68		
LOBBY CALL	69			LOBBY CALL	69		
	70				70		

Shaft 8 – Board 1 (Master)				Shaft 8- Board 2			
Relay No.	Board Terminals	Floor No.	Wire ID	Relay No.	Board Terminals	Floor No.	Wire ID
16	37			16	37		
	38				38		
15	39			15	39		
	40				40		
14	41			14	41		
	42				42		
3	43			13	43		
	44				44		
12	45			12	45		
	46				46		
11	47			11	47		
	48				48		
10	49			10	49		
	50				50		
9	51			9	51		
	52				52		
8	53			8	53		
	54				54		
7	55			7	55		
	56				56		
6	57			6	57		
	58				58		
5	59			5	59		
	60				60		
4	61			4	61		
	62				62		
3	63			3	63		
	64				64		
2	65			2	65		
	66				66		
1	67			1	67		
	68				68		
LOBBY CALL	69			LOBBY CALL	69		
	70				70		

Shaft 8 – Board 3				Shaft 8- Board 4			
Relay No.	Board Terminals	Floor No.	Wire ID	Relay No.	Board Terminals	Floor No.	Wire ID
16	37			16	37		
	38				38		
15	39			15	39		
	40				40		
14	41			14	41		
	42				42		
3	43			13	43		
	44				44		
12	45			12	45		
	46				46		
11	47			11	47		
	48				48		
10	49			10	49		
	50				50		
9	51			9	51		
	52				52		
8	53			8	53		
	54				54		
7	55			7	55		
	56				56		
6	57			6	57		
	58				58		
5	59			5	59		
	60				60		
4	61			4	61		
	62				62		
3	63			3	63		
	64				64		
2	65			2	65		
	66				66		
1	67			1	67		
	68				68		
LOBBY CALL	69			LOBBY CALL	69		
	70				70		