



Instructions for RS485 Relay Board

The RS485 Relay Board is designed to work with Access Plus systems. See reverse side for wiring information.

Setting the Relay Board Address

The only valid device addresses that can be used with the Access Plus system are 003 through 008. Each relay board must have a unique address and the addresses must start with 003 and continue in sequence. The type of device (card reader, keypad, etc.) connected to the relay board does not matter, only the address matters.

Switch SW4 and rotary switches SW2 and SW3 are used to set the address on the relay board. Since the address on the board must be set between 003 and 008, SW4 is left in the OFF position and SW2 is set to 0. You only need to set SW3 for the address of the device (003 – 008).

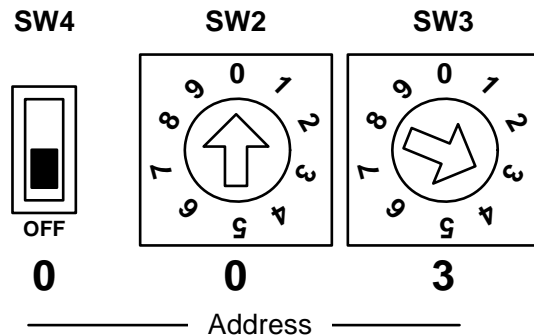

In the example at right, the relay board address is set for 003.

Each relay board must have a unique address and continue in sequence. Do Not Skip an address.

The order in which the relay board is connected to the Access Plus system does not matter. What is important is that the addresses must be in sequence starting with 003.

Wiegand Connections

The RS-485 Relay Board (2354-010) accepts input from 26-bit wiegand devices and then converts this data to RS-485 protocol for communication with the Access Plus system. The maximum distance that wiegand data lines can be run is 500 feet.

Using the 2354-010 circuit board, you can connect most 26-bit wiegand devices for use with the Access Plus system.

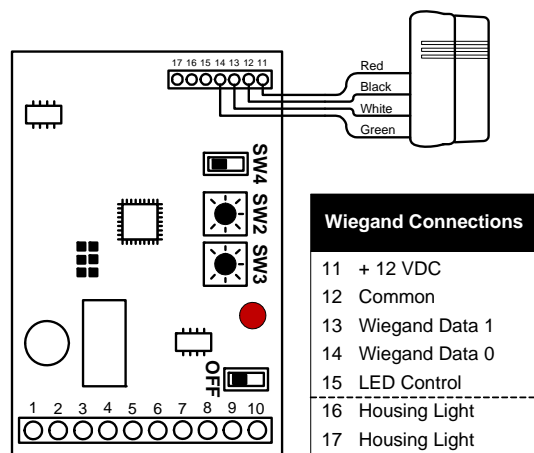

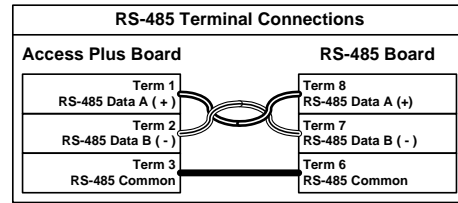
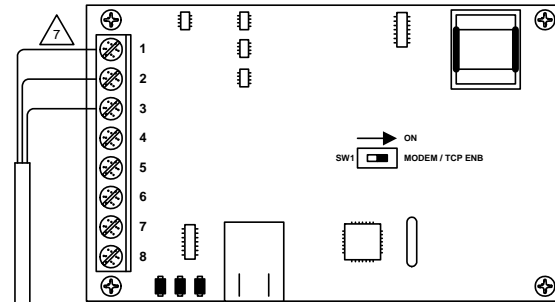

Terminal 1 from the Access Plus board connects to RS-485 board(s) terminal 8.
Terminal 2 from the Access Plus board connects to RS-485 board(s) terminal 7.
Terminal 3 from the Access Plus board connects to RS-485 board(s) terminal 6.

Wires connecting terminals 1 & 2 to terminals 8 & 7 MUST be twisted.

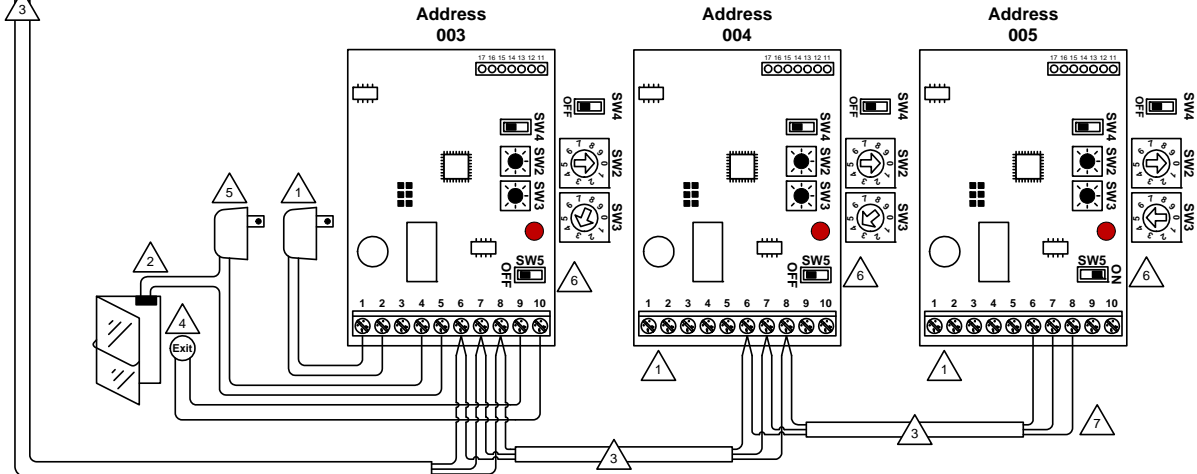

Terminals	
1	12-24 Volt AC/DC (-)
2	12-24 Volt AC/DC (+)
3	Relay Normally Open (N.O.)
4	Relay Normally Closed (N.C.)
5	Relay Common
6	RS485 Gnd
7	RS485 Data (B)
8	RS485 Data (A)
9	Request to Exit Com
10	Request to Exit Input

- 1 12 – 24 Volt, AC or DC power. Do not power from 1812 Unit. Must be supplied with its own power source as shown.
- 2 Magnetic locks are wired to the Normally Closed relay contacts. Electric strikes are wired to the Normally Open relay contacts.
- 3 The wires connected from the Access Plus board (terminals 1 & 2) to the RS-485 boards (terminals 8 & 7) MUST be twisted. We recommend that you use Cat5e cable. Use one pair to these terminals and then one wire from one of the other pairs to connect terminal 6. If wiring will be outdoors or underground, use Cat5e Gel Filled (flooded) UV Resistant Direct Burial Cable.

- 4 A switch closure across terminals 9 & 10 will activate the relay for its programmed strike time.
- 5 Lock power. Do not power magnetic locks or electric strikes from the RS-485 circuit board power source. Locks must be powered from their own source.
- 6 SW 5 is in the OFF position for middle units, and in the ON position for end units. If terminals 6, 7 & 8 have two wires connected to them, the SW 5 must be OFF. If terminals 6, 7 & 8 have only a single wire connected, the SW 5 must be ON.
- 7 Maximum distance from end to end is 4000 feet in a Daisy Chain format as shown in the diagram at right.

